

TITLE 178 WATER WELL STANDARDS

CHAPTER 12 WATER WELL CONSTRUCTION, PUMP INSTALLATION, AND WATER
WELL DECOMMISSIONING STANDARDS

12-001 SCOPE AND AUTHORITY: These regulations apply to the construction, location, and decommissioning of water wells, the installation of pumps and pumping equipment, the collection of water samples from water wells, and the inspection of installed water well equipment and chemigation regulation devices. The statutory authority is found in Neb. Rev. Stat. §§ 46-1201 to 46-1241, and 46-602. **These are minimum requirements.** Local requirements may be more stringent.

12-001.01 Related Regulations: Persons doing the work referenced above must be aware that other statutes and regulations may apply, including but not limited to:

1. Nebraska Department of Health and Human Services Title 179, Regulations Governing Public Water Systems;
2. Nebraska Department of Natural Resources (NDNR) Chapter 46, Article 6;
3. Nebraska Department of Environmental Quality (NDEQ) Title 122 Rules and Regulations for Underground Injection and Mineral Production Wells;
4. NDEQ Title 135 Rules and Regulations for Mineral Exploration Holes;
5. NDEQ Title 128 Rules and Regulations Governing Hazardous Waste Management in Nebraska;
6. NDEQ Title 130 Rules and Regulations for Livestock Waste Control;
7. Nebraska Natural Resources Districts (NRD) regulations; and
8. State Electrical Code.

12-002 DEFINITIONS

Abandoned Water Well means any water well (1) the use of which has been accomplished or permanently discontinued, (2) which has been decommissioned as described in the rules and regulations of the Department of Health and Human Services, and (3) for which the notice of abandonment required by Neb Rev. Stat. §46-602(2) has been filed with the Department of Natural Resources by the licensed water well contractor or pump installation contractor who decommissioned the water well or by the water well owner if the owner decommissioned the water well.

Annular Fill means materials placed in the annular space between the surface seal required in NAC 12-003.08C and the primary aquifer seal required in NAC 12-003.08A.

Annular Space means the space between the well casing and the well borehole wall and/or the space between two or more strings of well casing.

Aquifer means a geological formation, group of formations, or part of a formation that contains sufficient saturated permeable material to yield significant quantities of water to wells and springs.

Aquifer Seal

Primary Aquifer Seal means a non-slurry bentonite or high solids bentonite grout interval placed in the annular space on top of the gravel pack just above the screened openings, and/or beginning at the base of the first layer of silt/clay above the production zone, and/or at or immediately below the static water level, whichever provides the most aquifer protection.

Surface Seal means a grout interval placed in the annular space within the first 15 feet below surface.

Backflow Preventer means an assembly, a device, or a construction practice that prohibits the backflow of water from the distribution piping into the water well. This includes but is not limited to check valves, curb stops, or air gaps.

Bentonite means a highly plastic, colloidal sodium clay composed largely of montmorillonite.

Bentonite Seal means a viscous bentonite based material used as a seal or plug.

Bored or Dug Well means a well consisting of a large diameter borehole, usually two feet or more, lined with concrete, clay tile, brick, or stone.

Casing means a structural retainer which is installed in the borehole to support loose formation, provide a conduit for movement of fluids, and/or house pumping equipment.

Cesspool means an underground catch and discharge basin for household sewage or other liquid waste.

Clay means a fine grained inorganic material (grains less than 0.0005 mm in diameter) which has very low permeability.

Community Water System means a public water system that (a) serves at least 15 service connections used by year-round residents of the area served by the system or (b) regularly serves at least 25 year-round residents. (Neb. Rev. Stat. §71-5301)

Confining Layer means a geologic layer of either unconsolidated or consolidated material having permeability distinctly lower than the adjacent aquifer(s).

Construction of Water Wells means and includes all acts necessary to make a water well usable for the purpose for which it is intended including, without limitation, the siting of and excavation for the water well and its construction, alteration, or repair, but excluding the installation of pumps and pumping equipment.

Contamination means the addition of unwholesome or undesirable parts that render the larger whole physically unclean or impure.

Decommissioned when used in relation to a water well, means the act of filling, sealing, and plugging a water well in accordance with the rules and regulations of the Department.

Department means the Department of Health and Human Services.

Dewatering Well means a water well constructed for the purpose of lowering the ground water surface elevation, either temporarily or permanently.

Discharge Pipe means any and all piping beginning at the discharge head, or pitless unit tapping, extending to the first backflow prevention device.

Distribution Piping means all piping extending beyond the discharge pipe.

Driven Sandpoint Well means a well that is driven, washed or jetted into an aquifer with the sandpoint attached directly to the pump suction line.

Good Cause means a substantial reason consistent with the purposes of the Water Well Standards and Contractors' Practice Act.

Gravel Pack means filter material placed in the annular space around the well screen.

Ground Water means water below the surface of the ground.

Ground Water Heat Pump Well means a well constructed for the purpose of utilizing the geothermal properties of the ground.

1. Open Loop Heat Pump Well means a well that transfers heat via pumped ground water which is discharged above and/or below ground. For below ground discharge refer to NDEQ Title 122.
2. Closed Loop Heat Pump Well means a well constructed for the purpose of installing the underground piping necessary to recirculate heat transfer fluid.
 - a. Horizontal Closed Loop System means a boring, trench, or pit essentially parallel to the horizon and into which a closed loop pipe is placed for the purpose of utilizing the geothermal properties of the ground.

- b. Vertical Closed Loop System means a borehole essentially perpendicular to the horizon into which a closed loop pipe is placed and includes the horizontal closed loop header piping for the purpose of utilizing the geothermal properties of the ground.

Grout means materials composed of bentonite clays and/or portland cements, and if needed, other additives that when combined form a low permeability seal not greater than 1×10^{-7} cm/sec. Grout material is designed to seal the annular space when used for well construction and the well cavity when used for decommissioning.

Illegal Water Well means any water well which has not been properly decommissioned and which meets any of the following conditions:

1. The water well is in such a condition that it cannot be placed in active or inactive status;
2. Any necessary operating equipment has been removed and the well has not been placed in inactive status;
3. The water well is in such a state of disrepair that continued use for the purpose for which it was constructed is impractical;
4. The water well was constructed after October 1, 1986, but not constructed by a licensed water well contractor or by an individual on land owned by him/her and used by him/her for farming, ranching, or agricultural purposes or as his/her place of abode;
5. The water well poses a health or safety hazard;
6. The water well is an illegal water well in accordance with Neb. Rev. Stat. § 46-706; or
7. The water well has been constructed after October 1, 1986, and such well is not in compliance with the standards developed under the Water Well Standards and Contractors' Practice Act.

Inactive Status Water Well means a water well that is in a good state of repair and for which the owner has provided evidence of intent for future use by maintaining the water well in a manner which meets the following requirements:

1. The water well does not allow impairment of the water quality in the water well or of the ground water encountered by the water well;
2. The top of the water well or water well casing has a watertight welded or threaded cover or some other watertight means to prevent its removal without the use of equipment or tools to prevent unauthorized access, to prevent a safety hazard to humans and animals, and to prevent illegal disposal of wastes or contaminants into the water well;
3. All entrances and discharge piping to the water well are effectively sealed to prevent the entrance of contaminants; and
4. The water well is marked so as to be easily visible and located and is labeled or otherwise marked so as to be easily identified as a water well and the area surrounding the water well is kept clear of brush, debris, and waste material.

Injection Well means a well into which fluids are injected (regulated under NDEQ Title 122).

Installation of Pumps and Pumping Equipment means the procedure employed in the placement and preparation for operation of pumps and pumping equipment at the water well location, including connecting all wiring to the first control and all construction or repair involved in making entrance to the water well, which involves the breaking of the well seal.

Monitoring Well means a well constructed for purposes of monitoring water quality and/or quantity.

Non-potable Well means a water well constructed to produce water not intended for human consumption.

Observation Well means a non-potable water well constructed for the purpose of measuring water levels and/or collecting water quality samples that is not located in a zone of contamination.

Open Hole Well means a water well that results from the drilling of a hole into certain rock formations and often finished with no casing or screen adjacent to the water-yielding portion of the rock.

Person means any: Individual; partnership; limited liability company; association, public or private corporation; trustee; receiver; assignee; agent; municipality or other governmental subdivision, public agency; other legal entity; or any officer or governing or managing body of any public or private corporation, municipality, governmental subdivision, public agency, or other legal entity.

Pitless Unit means an underground discharge assembly for a water well which attaches directly to the casing and provides watertight subsurface connections for suction lines or pump discharge without the use of a well pit and includes the underground distributor and the steel extension to the ground surface.

Pollution means an impairment of water quality to a degree that restricts the intended use of ground water.

Potable Well means a water well constructed to produce water for human consumption.

Primary Aquifer Seal means a non-slurry bentonite or high solids bentonite slurry grout interval placed in the annular space on top of the gravel pack just above the screened openings, and/or beginning at the base of the first layer of silt/clay above the production zone, and/or at or immediately below the static water level, whichever provides the most aquifer protection.

Public Water System means a system for providing the public with water for human consumption through pipes or, after August 5, 1998, other constructed conveyances, if such system has at least 15 service connections or regularly serves an average of at least 25 individuals daily at least 60 days per year. Public water system includes (a) any collection,

treatment, storage, and distribution facilities under control of the operator of such system and used primarily in connection with such system and (b) any collection or pretreatment storage facilities not under such control which are used primarily in connection with such system. Public water system does not include a special irrigation district. A public water system is either a community water system or a non-community water system.

Service connection does not include a connection to a system that delivers water by a constructed conveyance other than a pipe if (i) the water is used exclusively for purposes other than residential uses, consisting of drinking, bathing, cooking, or other similar uses, (ii) the Department determines that alternative water to achieve the equivalent level of public health protection provided by the Nebraska Safe Drinking Water Act and rules and regulations under the act is provided for residential or similar uses for drinking and cooking, or (iii) the Department determines that the water provided for residential or similar uses for drinking, cooking, and bathing is centrally treated or treated at the point of entry by the provider, a pass-through entity, or the user to achieve the equivalent level of protection provided by the Nebraska Safe Drinking Water Act and the rules and regulations under the act.

Special Irrigation District means an irrigation district in existence prior to May 18, 1994, that provides primarily agricultural service through a piped water system with only incidental residential or similar use if the system or the residential or similar users of the system comply with exclusion provisions of subdivision (ii) or (iii) of this subdivision. (Neb. Rev. Stat. §71-5301.)

(Licensed) Pump Installation Contractor means an individual who has obtained a license from the Department and who is the principal officer, director, manager, or owner/operator of any business engaged in the installation of pumps and pumping equipment or the decommissioning of water wells.

(Licensed) Pump Installation Supervisor means an individual who has obtained a license from the Department and who is engaged in the installation of pumps and pumping equipment or the decommissioning of water wells. Such supervisor may have discretionary and supervisory authority over other employees of a pump installation contractor.

Pumps and Pumping Equipment means any equipment or materials utilized or intended for use in withdrawing or obtaining ground water including, but not limited to seals, tanks, fittings, and controls.

Recovery Well means a water well constructed for the purpose of, or in conjunction with, the removal of contamination from an aquifer or aquifers.

Sanitary Well Seal means a device used to cap a water well or to establish and maintain a junction between the casing or curbing of a water well and the piping or equipment installed therein, the purpose or function of which is to prevent pollutants from entering the water well.

Screen Apertures means a series of openings in a water well casing, made either before or after installation of the casing, to permit the entrance of water into the well.

Screened Vent means an inverted, U-shaped tube, or the equivalent, the open end of which is covered with a wire mesh, that is inserted into the top of a well to equalize the air pressure inside the well with that of the atmosphere.

Secure Cover or Cap means an object placed over a borehole or water well, the purpose of which is to prevent the degradation of ground water quality and/or personal injury.

Seepage Pit means a cavity into which sewage discharges and from which the discharge seeps into the surrounding soil.

Septic Tank means a covered, watertight receptacle for receiving sewage and liquid waste, for separating solids and liquids, for disintegrating organic material by bacterial action, and for discharging clarified liquid for final disposal.

Soil Absorption System (Septic Lateral Field) means a drain field, leaching area, or seepage bed including the effluent application/distribution system intended for the treatment of wastewater or disposal of effluent. The absorption system includes the infiltrative surface in the absorption trench and the soil between and around the trenches.

Static Water Level means the distance from the ground surface to the water level in a well when the well is not being pumped.

Substantially Equivalent means any procedure or material to be used for water well construction, pump installation, or water well decommissioning which provides equal protection to ground water resources from potential pollution and protects public health equivalent to the procedures or materials prescribed in 178 NAC 12.

Subsurface Disposal System means any system that utilizes the soil for subsequent absorption of treated sewage; such as a lateral field, absorption trench, seepage bed, or seepage pit.

Supervision or its derivatives means the ready availability of an individual licensed as a contractor or supervisor under the Water Well Standards and Contractors' Practice Act for consultation and direction of the activities of any individual not licensed who assists in the construction of a water well, the installation of pumps and pumping equipment, or decommissioning of a water well. Contact with the licensed contractor or supervisor by telecommunication is sufficient to show ready availability.

Surface Seal means a grout interval placed in the annular space within the first 15 feet below surface.

Test Hole means a hole or excavation designed to obtain information on hydrogeologic conditions.

Tremie Pipe means a pipe or hose that carries grout or gravel pack to the placement depth.

Watertight Casing means a watertight pipe that is of sufficient wall thickness to permit threading, gluing, or welding; is capable of withstanding the pressures exerted during installation and

forces imposed by the surrounding materials; and will resist corrosion by soil and water environments.

Watertight Secure Cover means a welded, solvent welded, threaded, or bolted watertight cover for a water well that is secured in such a way so as to prevent its removal without the use of tools.

Water Well means any excavation that is drilled, cored, bored, washed, driven, dug, jetted, or otherwise constructed for the purpose of exploring for ground water, monitoring ground water, utilizing the geothermal properties of the ground, obtaining hydrogeologic information, or extracting water from or injecting fluid as defined in Neb. Rev. Stat. §81-1502 into the underground water reservoir. Water well does not include any excavation described in Neb. Rev. Stat. §46-601.01 (1) (b) and (1) (c).

(Licensed) Water Well Contractor means any individual who has obtained a license from the Department and who is the principal officer, director, manager, or owner-operator of any business engaged in the construction or decommissioning of water wells.

(Licensed) Water Well Drilling Supervisor means any individual who has obtained a license from the Department and who is engaged in the construction or decommissioning of water wells. Such supervisor may have discretionary and supervisory authority over other employees of a water well contractor.

Well Development means the act of repairing alterations to the formation during construction of the well and enhancing the porosity and permeability of materials surrounding the intake portion of the well. The development process is the application of mechanical devices and/or the use of chemicals to remove drilling fluids and debris left in the filter pack and formation as a result of the drilling process.

Well Pit means a structure that is set at or below grade and houses a pump and/or pumping equipment and is large enough to allow an individual to fully enter the structure to work on such equipment and is not water tight.

Well Screen means the section of the well that allows water to pass from an aquifer into the well or from the well into an aquifer.

12-003 GENERAL REQUIREMENTS: These requirements apply to all water wells constructed under Title 178 NAC 12, except as modified in 178 NAC 12-004 through 12-014.

12-003.01 Protection and Location:

12-003.01A A well must not be located in a well pit.

12-003.01B Protection: All water wells must be protected from surface drainage, flooding and seepage from sources of contamination and pollution by:

1. Locating the well site to promote drainage away from the well, and

2. Terminating the top of the well and vent above the 100 year flood plain, or
3. Locating on a berm and/or within a dike to protect the well from a 100 year flood, or
4. Plugging the vent and seal at the top of the well if yield is less than 50 GPM.

12-003.01C Separation distances must at a minimum comply with the distances listed in Chart 1 (or Chart 2 if the requirements in 178 NAC 12-003.01C item 2 are met). Be aware that other state, NRD, and local statutes and regulations may have more restrictive requirements. If locations are found to not comply with more stringent standards of other state or local regulations that apply, the Department may notify the appropriate authority.

1. All water wells except those covered in 178 NAC 12-007 must meet the minimum separation distances in accordance with Chart 1 below.

Chart 1

Minimum Distance in Feet	From
1,000	Any Title 179 community water supply wells under different ownership
1,000	Any industrial wells under different ownership
600	Any irrigation wells under different ownership
100	Any waste water lagoon
100	Any privy, cesspool, subsurface disposal system
100	Any septic lateral field (soil absorption system)
100	Any animal waste containment structure
100	Any holding pens of animals
100	Any other known sources of contamination or pollution
50	Any sewer line
50	Any septic tank
10	Any depression that could retain stagnant water
10	Any storm water way
10	Any frost proof hydrant
10	Any well pit

2. A well driller may locate a well as indicated in Chart 2 below only if:
 - a. Compliance with the separation distances established in Chart 1 cannot be met; and
 - b. The well driller notifies the Department in writing of his/her intent and receives Department written approval prior to construction; and
 - c. The water well is grouted the full length of the annular space from immediately above the gravel pack above the screened openings to the surface with chip bentonite; and
 - d. The subsurface geology includes sufficient silts and/or clays that will provide a protective seal to the groundwater when combined with chip bentonite.

Chart 2

These Separation Distances Require Prior Written Approval from the Department	
Distance in Feet	From
50-100	Any waste water lagoon
50-100	Any privy, cesspool and subsurface disposal system
50-100	Any septic lateral field (soil absorption system)
50-100	Any animal waste containment structure
50-100	Any holding pens of animals
50-100	Any other known sources of contamination or pollution
25-50	Any sewer line
25-50	Any septic tank
5-10	Any depression that could retain stagnant water
5-10	Any storm water way
5-10	Any frost proof hydrant

3. If a person wants to locate a well closer than the listed separation distances in Chart 2, a declaratory order request may be submitted to the Department so the Department can determine if the proposal is substantially equivalent to the regulations.

12-003.02 Sanitation: All water wells must be constructed to prevent the introduction of biological, chemical or radiological substances which may degrade the ground water.

12-003.02A Drilling Equipment: The water well contractor must use precautions to ensure that all down hole equipment used in the construction of water wells is free of contaminated or polluted materials.

12-003.02B Secure Cover: All water wells must be protected with a secure cover or cap. All inactive water wells must be capped with a watertight secure cover. When the pump is in place, it must be made secure and watertight in accordance with 12-011.03D.

12-003.03 Well Screens

12-003.03A Materials: Well screens must be constructed of durable non-toxic materials of sufficient strength to withstand the pressure to which they may be subjected. They must also be resistant to any corrosion which may result from the characteristics of the water and aquifer materials in which they are placed.

12-003.03B Screen Apertures: Screen apertures must be formed by the continuous slot method, louver, punched casing, molded or mill slotted. Torch slotted casing must not be used. The method of construction must allow for control of aperture width. In general, the aperture width should retain a minimum of 85% of the gravel pack, if used, or a minimum of 50% of the aquifer material if gravel pack is not used.

12-003.04 Well Casing: All wells other than test holes and closed loop heat pump wells must be cased. Well casing must be composed of nontoxic durable material compatible with the water quality encountered.

12-003.04A Casing Wall Thickness: The wall thickness of water well casing must be sufficient to withstand the pressures exerted by the surrounding materials, forces imposed on it during installation, and corrosion by soil and water environments.

12-003.04B Casing Placement: The casing must be centered in the borehole in areas of grout so there is a minimum 2-inch uniform annular space.

12-003.04C Watertight Casing must be constructed of steel, PVC, fiberglass, or teflon and must be manufactured expressly for water well casing.

12-003.05 Gravel Pack

12-003.05A Gravel Pack must consist of clean sand or gravel of selected grain size and gradation.

12-003.05B Gravel Pack, Screen Size, and Gradation must be determined based upon the grain size and gradation of the portion or portions of the aquifer to be screened. Gravel pack must be designed to stabilize the aquifer material and to permit the fine fraction to move into the water well during development. Gravel pack, when used, must extend to a length equal to at least 2.5 times the casing diameter above the screen apertures.

12-003.06 Grout: Cement based grouts must not contain fly ash. The Department has approved the following grout materials:

1. Neat Cement Grout Slurry which must consist of a mixture of portland cement and no more than 5.2 gallons of clean water per bag (1 cubic foot or 94 pounds) of cement. Non-toxic additives may be used to minimize shrinkage and cracking.
2. Sand Cement Grout Slurry which must consist of a mixture of portland cement, sand and water in the proportion of no more than 2 parts by weight of sand to 1 part of cement with no more than 6 gallons of clean water per bag of cement (1 cubic foot or 94 pounds).
3. Non-slurry Bentonite Grout which must consist of chip, chunk or pelletized bentonite varieties that are hydrated to manufacturer's specifications.
4. Cement/Bentonite Grout Slurry which must consist of a mixture of portland cement and bentonite in the following proportion: no more than 6.5 gallons of water and 3 to 5 pounds of bentonite per 94-pound sack of portland cement.
5. High Solids Bentonite Grout Slurry which must consist of an inorganic mixture of:
 - a. Soda ash for pre-treatment of makeup water, and
 - b. Minimum of 20% by weight active solids bentonite-to-water ratio, and
 - c. Fine to medium grade sand added at a minimum ratio of 4:1 sand to bentonite by weight, and if needed
 - d. Additives designed for yield/rate control for bentonite products that form a low permeability seal not greater than 1×10^{-7} cm/sec which resists flow of fluid through the seal, is pumpable, and is mixed to the manufacturer's specifications.
6. Bentonite Grout Slurry which must consist of an inorganic mixture of:
 - a. Soda ash for pretreatment of makeup water, and
 - b. Minimum of 20% solids by weight bentonite that forms a low permeability seal not greater than 1×10^{-7} cm/sec which resists flow of fluid through the seal, is pumpable, and is mixed to the manufacturer's specifications, and if needed
 - c. Additives designed for yield/rate control for bentonite products that form a low permeability seal not greater than 1×10^{-7} cm/sec which resists flow of fluid through the seal, is pumpable, and is mixed to the manufacturer's specifications.

12-003.07 Placement of Grout

12-003.07A Slurry Grout: All grout slurries must be placed by tremie or by pumping. Cement based grout must not be allowed to free-fall more than 10 feet. Cement based grout must be separated from bentonite grouts by a 2-4 foot interval of fine sand.

12-003.07B Non-slurry Grout: Pellet, chip, chunk bentonite or any combination of those materials must be placed, measured frequently, and hydrated, before installing another interval to confirm the grout is placed without bridging and provides a tight homogeneous seal.

12-003.08 Aquifer Protection: All water wells must be filled and sealed in a manner that protects the water bearing formations from contamination from surface runoff and from subsurface contaminants.

12-003.08A Primary Aquifer Seal: All water wells, except (a) bored wells (178 NAC 12-004.04 and 12-005.03), (b) temporary dewatering wells (178 NAC 12-006.02), and (c) wells that require surface casing and additional gravel pack throughout the life of the well (178 NAC 12-005.05) must have a 5 foot primary aquifer seal of non-slurry bentonite or high solids bentonite slurry as defined in 178 NAC 12-003.06 items 3 and 5, respectively. The primary aquifer seal must be placed in the borehole at one or more of the following locations to provide optimal aquifer protection.

1. On top of the gravel pack just above the screened openings (See Figure 1A), and/or
2. Beginning at the base of the first layer of silt/clay above the production zone (See Figure 1B), and/or
3. At/or immediately below the static water level. (See Figure 1C)

12-003.08B Filling the Annular Space: The annular space of all wells except closed loop heat pump wells that are part of a closed loop heat pump system in 178 NAC 12-010.03C must be filled from the top of the primary aquifer seal to the bottom of the surface seal (12-003.08C) with:

1. Non-slurry bentonite grout, or
2. Non-slurry bentonite grout mixed with gravel pack in a 1:1 ratio by weight, or
3. Sand and granular bentonite mixed in a 2:1 sand-to-bentonite ratio by weight, or
4. High solids bentonite slurry as defined in 12-003.06 item 6, or
5. A mixture of bentonite/clay, drilling fluid, and gravel pack, or
6. Cement based grouts.

12-003.08C Surface Seal: The annular space of all wells, except bored wells and temporary dewatering wells, must have at least 5 feet of non-slurry bentonite, high solids bentonite slurry, or sand cement grout placed between 5 and 15 feet below

grade or at the static water level, whichever is less (See Figure 2A). If a pitless unit is used to terminate the top of the well, the surface seal must extend 5 feet down the borehole below the bottom of the pitless adapter (See Figure 2B).

12-003.08D Above Ground Protection: Cased water wells that terminate in a pump house must be protected with a concrete floor measuring a minimum of 4 inches thick by 12 inches beyond the borehole wall and sloping away from the water well. Watertight casing must extend 12 inches above the floor of the pump house.

12-003.08E Surface Completion: The earth surrounding the casing must slope away from the water well and must be firmly tamped to prevent water from seeping down around the casing.

12-003.09 Well Development: All cased water wells must be developed to repair the alterations to the formation during the construction of the well and to enhance the porosity and permeability of materials surrounding the intake portion of the well. The development process is the application of mechanical devices and/or the use of chemicals to remove drilling fluids and debris left in the filter pack and formation as a result of the drilling process.

12-003.10 Test Pumping a Well: Test pumping must be utilized to determine the most efficient production rate for the well. The pumping water level must be recorded during the period of test pumping.

12-003.11 Repairing a Well: Only the portion(s) of a well being repaired must meet the same minimum standards as it would if it were within a new well with regard to design, construction, and material. Bored and dug wells must be repaired so that they meet the standards of a bored well. (See Figure 3.)

12-003.12 Well Logs: Any owner of a water well or any licensed water well contractor who engages in the act of or business of constructing a water well must keep and maintain an accurate well log of the construction of each water well and test hole. A licensed water well contractor must forward a copy of the well log to the owner.

12-003.12A Required Information: The well log must include the following information:

1. Legal description and the GPS coordinates of the location of the water well or test hole;
2. Description and depth of geologic materials encountered;
3. Depth and diameter or dimension of constructed water well and test hole;
4. Diameter and depth or dimension of excavated hole if applicable;
5. Depth and volume of formation stabilizer or gravel pack and size of particles, if used;
6. Depth and thickness (intervals and volume) of grout or other sealing material if applicable;

7. Casing and/or loop pipe information, including length, inside and outside diameter (ID and OD), wall thickness, and type of material if applicable;
8. Screen information, including length, trade name, inside and outside diameter, slot size and type of material if applicable;
9. Static water level;
10. Water level when pumped at the designed rate giving the rate of pumping and amount of time pumped, if applicable;
11. Yield of water well in gallons per minute or gallons per hour if applicable;
12. Signature of water well contractor;
13. Dates drilling commenced and construction completed;
14. Intended use of the water well;
15. Name and address of the landowner;
16. Identification number of any permit for the water well issued pursuant to Neb. Rev. Stat. § 46-601 et seq. or Neb. Rev. Stat. § 66-1101 et seq., and
17. Name, address, and license number of any license issued pursuant to the Water Well Standards and Contractors' Practice Act of any individual, other than the owner of the water well, who constructed the water well.

12-003.12B Availability for Inspection: The well log must be available to the Department for inspection and copying during reasonable hours or the regular business hours of the contractor.

12-003.13 Registration: A licensed water well contractor must register all wells with the Nebraska Department of Natural Resources on forms provided by that Department, except as otherwise provided by Neb. Rev. Stat. § 46-602.

12-004 POTABLE WELL CONSTRUCTION: A water well contractor must verify the purpose of a new well with the owner or the system's engineer. If the well is to serve water to the public, see 178 NAC 12-008.

12-004.01 Construction of Potable Well:

1. A potable water well to be used for human consumption must not be constructed as a driven sandpoint well.
2. It must meet the requirements specified in 178 NAC 12-003.

12-004.02 Casing a Potable Well: A potable water well must be cased with unused watertight casing in the following manner:

12-004.02A The top of the well must extend at least 12 inches above the grade of the land surface. The earth surrounding the well must slope away from the well and must be firmly tamped to prevent water from seeping down the casing.

12-004.02B Non-steel cased wells must be fitted with a watertight connection to .237 inch wall minimum steel casing through the frost zone, unless terminating in a pump house.

12-004.02C Non-steel watertight casing must be manufactured expressly for well casing, and must meet the following specific requirements:

1. Casing strength must be not less than 160 pounds per square inch or Standard Dimension Ratio (SDR) 26.
2. Plastic or other non-steel casing must bear the National Sanitation Foundation (NSF) 61 stamp of approval.

12-004.02D Special Engineered (SE) plastic piping systems must meet the requirements of 178 NAC 12-004.02C item 2.

12-004.02E Packaging of thread compounds, sealants and lubricants must bear the NSF Standard 61 stamp of approval.

12-004.03 Potable Well Shock Decontamination

12-004.03A When a well which will produce water for human consumption is constructed or altered, it must be decontaminated.

12-004.03B The water well contractor/pump installation contractor must supply the landowner with an informational brochure that tells the owner why s/he should test his/her water and what the results mean.

12-004.03AC Shock decontamination must be accomplished by:

1. Using a solution equivalent to 200 parts per million chlorine (See Table 1);
2. Pouring the solution directly into the well; splashing the well pump, piping, casing, and other well equipment as much as possible; agitating the water in the well by surging the pump or by other means to mix the solution with the water or recirculating the water into the well, always washing down the casing or drop pipe;
3. Letting the mixture stand in the well for a minimum of 4 hours;
4. Opening all water taps and pumping the well until evidence of the solution is detected at all taps. The system must be allowed to stand idle for a minimum of 2 additional hours and then the entire system must be flushed to waste.

12-004.04 Bored (Seep or Cistern) Wells must be constructed to the same minimum standards for potable wells with the following exceptions: (See Figure 3)

12-004.04A Casing materials may be concrete, tile, or other material approved in 178 NAC 12-003.04C.

12-004.04B The annular space below the surface seal must be filled with gravel.

12-004.04C Watertight casing and grout must be placed from 10 feet below the surface or the static water level, whichever is less, to the surface or the bottom of the pitless unit. (See Figure 3)

12-004.05 Open Hole Wells must be constructed to the same minimum standards for potable wells and in the following manner. (See Figure 4)

12-004.05A The casing must extend at least 2 feet into the open borehole. A seal must be created between the casing and the lower borehole to ensure that the annular fill material remains in the upper borehole. This can be accomplished by using a collar attached to the casing, a drive shoe, or other sealing device.

12-004.05B A minimum 5 foot primary aquifer seal must be placed in the annular space directly above the collar, drive shoe, or other sealing device.

12-004.05C Open Hole Wells in Multiple Aquifers must be constructed to the same minimum standards for potable wells and must comply with 178 NAC 12-004.05A and 12-004.05B. The screened section must be gravel packed. The gravel pack must extend both above and below the screen for a length equal to 2.5 times the diameter of the well. A 5 foot minimum primary aquifer seal must be placed directly above the gravel pack. (See Figure 5)

12-005 NON-POTABLE WELLS

12-005.01 Construction of a Non-Potable Well

12-005.01A Driven sandpoint wells are permitted only for temporary use and must be decommissioned within 90 days of installation. They must meet the requirements specified in 178 NAC 12-003.

12-005.01B Observation wells must be located as required in 178 NAC 12-003.01C item 1.

12-005.02 Casing a Non-Potable Well: A non-potable water well must be cased with unused watertight casing in the following manner:

12-005.02A Cased wells with an outside diameter (OD) of 6-5/8 inches or less

12-005.02A1 The top of the well must extend at least 12 inches above the grade of the land surface. The earth surrounding the well must slope away from the well and must be firmly tamped to prevent settling around the casing.

12-005.02A2 Non-steel cased wells must be fitted with a watertight connection to 0.237 inch wall minimum steel casing or fitted inside a metal sleeve secured and cemented in the borehole through the frost zone. The annular space between the metal sleeve and the casing must be a minimum of 2 inches and must be filled with an approved grout (178 NAC 12-003.06) or annular fill (12-003.08B). (See Figures 6 and 7)

12-005.02A3 Above Ground Protection for Observation Wells: Non-steel cased wells completed above ground must be enclosed with a 5-5/8 inch minimum metal casing/sleeve, buried a minimum of 2-1/2 feet below the ground surface, and covered with an overlapping, vandal-resistant secured metal cap.

12-005.02B Cased Wells with an OD Larger than 6-5/8 Inches

12-005.02B1 The casing must extend a minimum of 6 inches above the grade of the land surface. (See Figure 8)

12-005.02B2 The well must have a concrete pad a minimum of 40 inches by 40 inches by 8 inches thick. Prefabricated slabs are acceptable. The concrete must contact the entire circumference of the casing. (See Figure 8)

12-005.02C The earth surrounding the well must slope away from the well and must be firmly tamped to prevent settling around the casing. (See Figure 8)

12-005.02D Watertight steel casing must be a minimum of 0.188 inch wall thickness.

12-005.02E Watertight non-steel casing must be manufactured expressly for well casing and must meet the following specific requirements:

1. Casing strength must not be less than 160 pounds per square inch or Standard Dimension Ratio (SDR) 26 for 8-5/8 inch or less OD casing. Casing strength must not be less than schedule 40 for casing larger than 8-5/8 inches OD; and
2. Non-steel casing must bear the National Sanitation Foundation (NSF) 61 stamp of approval.

12-005.02F Special Engineered (SE) plastic piping systems must meet the requirements of 178 NAC 12-005.02E item 2.

12-005.02G Packaging of thread compounds, sealants, and lubricants must bear the NSF 61 stamp of approval.

12-005.03 Bored (Seep or Cistern) Wells must be constructed to the same minimum standards for non-potable wells with the following exceptions: (See Figure 3.)

12-005.03A Casing may be concrete, tile, or other material approved in 178 NAC 12-003.04C;

12-005.03B The annular space must be filled with gravel;

12-005.03C Watertight casing is required and grout must be placed from 10 feet below the surface or the static water level, whichever is less, to the surface or the bottom of the pitless unit.

12-005.04 Open Hole Wells must be constructed to the same minimum standards for non-potable wells and in the following manner. (See Figure 4.)

12-005.04A The casing must extend at least 2 feet into the open borehole. A seal must be created between the casing and the lower borehole to ensure that the annular fill material remains in the upper borehole. This can be accomplished by using a collar attached to the casing, a drive shoe, or other sealing device.

12-005.04B A minimum 5 foot primary aquifer seal must be placed in the annular space directly above the collar, drive shoe, or other sealing device.

12-005.04C Open Hole Wells in Multiple Aquifers must be constructed to the same minimum standards for non-potable wells and must comply with 178 NAC 12-005.04A and 12-005.04B. The screened section must be gravel packed. The area of gravel pack must extend both above and below the screen for a length equal to 2.5 times the diameter of the well. A minimum 5 foot primary aquifer seal must be placed directly above the gravel pack. (See Figure 5.)

12-005.05 Wells Located in the Arikaree Formation Subject to Subsidence must be constructed to the same minimum standards as non-potable wells with the following exceptions. (See Figure 9)

12-005.05A The borehole for the surface casing must allow for a uniform annular space of 4 inches or larger than the surface casing;

12-005.05B A minimum 6 inch annular space must exist between the surface casing and the well casing to provide for gravel placement.

12-005.05C The metal surface casing must be a minimum of 20 feet in length.

12-005.05D A minimum of 5 feet of concrete must be placed between the borehole wall and the surface casing and allowed to set, encasing the bottom 5 feet of surface casing.

12-005.05E A minimum layer of 5 feet of non-slurry bentonite must be placed between the borehole wall and the surface casing above the concrete, with an additional 5 feet of concrete placed on top of the non-slurry bentonite. The concrete must be set prior to drilling inside the surface casing.

12-005.05F The metal gravel chute must be straight and a minimum of 6-5/8 inches OD. The top of the chute must extend a minimum of 6 inches above the concrete pad and be equipped with a vandal resistant, secure cover or cap. The bottom of the gravel chute must extend from the surface casing a minimum of 2 feet below grade. The gravel chute and the upper 5 feet of surface casing must be encased in concrete.

12-005.05G The concrete pad must extend a minimum of 12 inches beyond the surface casing borehole and be a minimum of 5 feet by 5 feet which surrounds the gravel chute. The thickness must be a minimum of 12 inches above grade and an additional minimum of 12 inches below grade within the boreholes.

12-006 DEWATERING WELLS

12-006.01 Permanent Installation: Permanently constructed dewatering wells must be constructed to the same standards as non-potable wells.

12-006.02 Temporary Installations: Temporary installations must be constructed in a manner that prevents the introduction of contaminants into the ground water. They must be decommissioned within 90 days of installation.

12-006.02A Location: Dewatering wells must be located or the site graded so that surface drainage is away from the well.

12-006.02B Sanitation: Temporary dewatering wells must be constructed to prevent the introduction of microbiological, chemical, or radiological substances which may be toxic into the aquifer or aquifers penetrated.

12-006.02C Well Screens must be composed of nontoxic, durable material.

12-006.02D Temporary Casing: Casing and screen may be re-used.

12-006.02E Casing Wall Thickness: The wall thickness of temporary dewatering well casing must be sufficient to withstand the forces imposed on it during installation and pressures exerted on it by the surrounding materials.

12-006.02F Secure Cover: Any temporary dewatering well which is under construction must be protected with a secure cover or cap when it is unattended.

12-006.02G Repair of a Dewatering Well: All temporary dewatering well repairs must be done in accordance with current standards.

12-007 GROUND WATER MONITORING AND RECOVERY WELLS must be constructed in the following manner.

12-007.01 Well Screens: The top of the screen aperture may extend to within 2 feet of the land surface. The gravel pack thickness may be reduced so as to not compromise the surface seal.

12-007.02 Watertight Well Casing

12-007.02A Casing must be composed of nontoxic durable material compatible with water quality encountered.

12-007.02B Wells must be cased with watertight casing through required areas of grout. The watertight casing must extend at least 12 inches above ground level except for construction in sidewalks, roadways, driveways, parking lots, other heavily trafficked areas, or wherever else the situation requires flush mounted installation with watertight caps.

12.007.02C Casing must be chemically resistant to all contaminants which are expected to be encountered.

12.007.02D Casing must be equipped with a watertight cap or plug in conjunction with both flush mount and above-ground protectors.

12-007.03 Grouting the Annular Space: A non-slurry bentonite seal with a minimum thickness of 5 feet must be placed on top of the gravel pack immediately above the screen. All wells must be grouted from immediately above the non-slurry bentonite seal/fine sand to the surface in accordance with 178 NAC 12-003.07.

12-007.04 Above Ground Protection: Non-steel cased wells completed above ground must be enclosed with a steel casing embedded in the concrete pad and covered with an overlapping, vandal-resistant secured metal cap.

12-007.05 Pad: Ground water monitoring and recovery wells must have a concrete pad extending a minimum of 1 foot past the walls of the original borehole and must be a minimum of 8 inches thick. The concrete must contact the entire circumference of the casing.

12-007.06 Well Logs: The location of each well must be shown on a site diagram in addition to the driller's log, to be provided in accordance with 178 NAC 12-003.12A.

12-007.07 Nested Well Design: Wells constructed for ground water investigations may use a nested design. (See Figure 10)

12-007.07A Individual casings must be separated vertically by a minimum of 2 feet of non-slurry bentonite grout between casings of different lengths within the borehole. A 1-foot minimum non-slurry bentonite grout must be placed on top of each gravel pack interval. The annular space must be grouted as per 178 NAC 12.003.06 and 12-003.07 between non-slurry bentonite grout and the next gravel pack interval.

12-007.07B Individual casings must be separated horizontally by a 2 inch annular space, including 2 inches between the outermost casing and the borehole wall.

12-007.08 Temporary Well Installation: A pre-notification document must be submitted to the Department 30 days before constructing a temporary well to be in use longer than 10 days (does not apply to temporary dewatering wells). The notification must indicate what type of surface seal will be provided. Temporary wells must be decommissioned within 90 days of installation and cannot be used as a monitoring, recovery, or test well on a permanent basis unless the construction complies with the provisions of Title 178 NAC 12-003.04B, or the well is granted a Declaratory Order in accordance with 178 NAC 12-013 before it is constructed.

12-008 PUBLIC WATER SUPPLY SYSTEMS: If a well is to serve water to the public, the contractor must verify if the well is to serve a community or a non-community system.

12-008.01 Community public water wells must be sited, constructed, and/or relined in accordance with Title 179 NAC 7 requirements, including Department-approved plans and specifications. Examples of community public water systems include, but are not limited to mobile home parks, subdivisions, and nursing homes or assisted living residences.

12-008.02 Non-community public water systems include, but are not limited to restaurants, gas stations, factories, schools, rest areas, and recreation camps. When a well is intended to be a non-community public water supply well, the contractor may drill the well in accordance with the requirements of 178 NAC 12 only when:

1. The capacity of the well is less than 100 gallons per minute (gpm), and the total system capacity of any associated bladder tank and piping does not exceed 200 gallons, and
2. The top of its well screen is greater than 50 feet from the original ground surface, and
3. The well is located more than 200 feet from surface water, and
4. The owner supplies the contractor with written confirmation from the Department that states the well may be drilled according to Title 178 NAC 12 standards.

12-008.03 Any public water system wells not meeting the criteria in 179 NAC 12-008.02 must be constructed in accordance with Title 179 NAC 7 plans and specifications prepared by a registered Nebraska engineer and approved by the Department.

12-009 TEST HOLES: Test holes, constructed in conjunction with ground water investigations must not be retained for more than 10 days, must be covered when not in use, and must be properly decommissioned within 10 days of drilling.

12-009.01 Location: A test hole must be located so that it is protected from surface waters and seepage from sources of contamination and pollution.

12-009.02 Surface Casing: When onsite conditions dictate, surface casing is permitted but must be protected with a secure cover or cap when left unattended, and decommissioned within 10 days of drilling completion.

12-010 GROUND WATER HEAT PUMP WELLS

12-010.01 Open Loop Heat Pump Wells:

1. Water wells intended only to withdraw water must comply with 178 NAC 12-004, Potable Water Wells.
2. Water wells intended only to inject ground water must comply with Nebraska Department of Environmental Quality's Title 122 – Rules and Regulations for Underground Injection and Mineral Production Wells.

12-010.02 Closed Loop Heat Pump Wells: Water wells for closed loop heat pump systems must be constructed in accordance with the following standards.

12-010.02A For a closed loop heat pump system that has 10 or more boreholes, the following information must be submitted to the Department a minimum of 14 working days prior to initial construction.

1. Location of project;
2. Name and address of licensed water well contractor supervising the installation of the heat pump system; and
3. A completed copy of the information referenced in 178 NAC 12-003.12A, showing proposed construction and installation of the closed loop heat pump system.

12-010.02B Location: All water wells constructed for closed loop heat pump systems must be located in accordance with 178 NAC 12-003.01.

12-010.02B1 Location from a Public Water System Well

12-010.02B1a The location of closed loop heat pump wells must comply with 178 NAC 12-003.01C item 1. Be aware that other state and local statutes and regulations may have more restrictive requirements. If locations do not comply with more stringent standards of other applicable state or local regulations, the Department may notify the appropriate authority, which could require the well to be decommissioned.

12-010.02B1b Water wells constructed for a closed loop heat pump system must be located more than 100 feet from a non-community public water system well.

12-010.02B1c A closed loop heat pump system must be located more than 1,000 feet from a community public water system well.

The Department will consider approval for location of closed loop heat pump wells at closer proximity than 1,000 feet horizontal separation distance, when the licensed professional engineer or licensed professional geologist representing the owner(s) of the closed loop heat pump wells, demonstrates to the Director or Director's designee that such location will not constitute a pollution hazard to the safety of the water supply, and that the owner(s) of the community water system has no objection to the location of the closed loop heat pump wells.

The engineer or geologist must submit the supporting data as appropriate to make a case for approval of the proposed location of heat pump wells to the Department 30 working days prior to the date on which action by the Director or Director's designee is desired. The contractor must not begin construction until the Department has approved the location.

12-010.02C Borehole Diameter: The borehole diameter of a closed loop heat pump well must be of sufficient size to allow placement of the pipe and placement of a tremie to emplace the grout. The borehole diameter must be a minimum of 4 inches larger than the total OD of the loop pipes.

12-010.02D Pipe: Pipe material must be composed of polyethylene, grade p34, minimum cell classifications PE 355434C or PE 345434C, when tested under ASTM Standard 3350, incorporated herein by reference. (ASTM standards are copyrighted and available from the American Society for Testing and Materials International, 1916 Race St., Philadelphia, PA 19103; Phone 215-299-5585, Fax 215-977-9679, 100 Barr Harbor Drive, P.O. Box C700, West Conshohocken, PA 19428-2959 USA; Phone: 610-832-9500; <http://www.astm.org>. Standards may be viewed during normal business hours at the Nebraska Department of Health and

Human Services, Division of Public Health, 301 Centennial Mall South, 3rd Floor, Lincoln, NE 68509.)

12-010.02E Pipe Joining Method: Heat fusion methods for pipe joining must be the socket or butt heat fusion technique as referenced in ASTM Standards D3261 or D2683, both of which are incorporated herein by reference. (ASTM standards are copyrighted and available from the American Society for Testing and Materials International, 100 Barr Harbor Drive, P.O. Box C700, West Conshohocken, PA 19428-2959 USA; phone: 610-832-9500; <http://www.astm.org>; OR standards may be viewed during normal business hours at the Nebraska Department of Health and Human Services, Division of Public Health, 301 Centennial Mall South, 3rd floor, Lincoln, NE 68509.)

12-010.02F Pressure Testing: The installed system must be pressure tested to a minimum of 100 pounds per square inch (psi). After 6 hours it is permissible for the pressure to drop a maximum of 15% of the initial psi due to expansion of the HDPE piping. A pressure loss greater than 15% in 6 hours is an indication of a leak in the circulating system. If a pressure loss is detected, the cause must be properly repaired, the material replaced, or the well must be properly decommissioned.

12-010.02G Purging a Loop System: After a loop system is installed and pressure tested, and prior to introducing additives to the circulating fluid, the entire loop, header and associated plumbing must be purged at a minimum rate of 5 feet per second to remove any debris that has entered the loop during construction.

12-010.02H Circulating Fluids: When food grade propylene glycol is added to water for antifreeze protection, it must be non-toxic in nature when combined with the circulating fluid additives in a closed loop heat pump system. If needed, the addition of corrosion inhibitors and biocides may be used in circulating fluid if such additives are also:

1. Non-toxic; and
2. Compatible with food grade propylene glycol; and
3. Non-hazardous materials upon disposal or a change of circulating fluid.

12-010.03 Completion of a Vertical Closed Loop System: Completion of a borehole for a closed loop heat pump well must be finished within 6 hours from the time the borehole is drilled. Drilling muds or cuttings cannot be used as completion materials. The tremie pipe must not be left in the borehole.

12-010.03A Systems that have 10 or more boreholes must be grouted full-length with high solids bentonite slurry in accordance with 178 NAC 12-003.06 item 5. (See Figure 11A)

12-010.03B Systems that have fewer than 10 boreholes must be grouted full-length with high solids bentonite slurry in accordance with 12-003.06 item 5 when they are

located less than 1000 feet of a community public water well (which requires prior written permission from the community). (See Figure 11B)

12-010.03C Systems that have fewer than 10 boreholes and are located 1000 feet or more from a community public water well must use one of the following methods to complete construction of the boreholes: (See Figure 11C)

1. High solids bentonite slurry that meets the requirements of 178 NAC 12.003.06 item 5 must be used to grout the full length of the borehole, or
2. Sand or gravel must be placed through the sodium bentonite fluid with a viscosity that allows the sand to settle through the fluid from the bottom of the borehole to the static water level by tremie or free fall method. A 5 foot interval of bentonite chips must be placed at the static water level, and the remainder of the borehole must be sand/gravel packed through the fluid to within 30 feet of the surface minus excavation for the header piping. The remaining annular space must be filled with non-slurry bentonite chips.

12-010.04 Horizontal Closed Loop System

12-010.04A A horizontal closed loop heat pump system that is constructed by trenching or digging is exempt from the grouting requirements of closed loop systems provided that no part of the horizontal loop is constructed at or below the ground water level.

12-010.04B A horizontal closed loop heat pump system constructed by boring or drilling must be grouted with high solids bentonite slurry grout that meets the requirements of NAC 12-003.06 item 5.

12-010.04C All other construction standards for closed loop heat pump wells in 178 NAC 12-010 apply.

12-011 INSTALLATION OF PUMPS AND PUMPING EQUIPMENT

12-011.01 General Requirements: The following are general requirements and apply to the installation of all pumps and pumping equipment not already regulated, such as public water systems under Title 179.

12-011.01A Contamination: Pumps and pumping equipment must be installed in a manner that prevents contaminants from entering the well.

12-011.01B Disinfection

12-011.01B1 Care must be taken so that all tools used in the removal of pumps and pumping equipment are disinfected periodically, or as needed. Disinfection solution must be equivalent to 50 parts per million chlorine

solution (See Table 2). It is not permissible to lay the drop pipe, pump, pumping equipment, or wire on the ground.

12-011.01B2 When a pump for a potable well is installed or repaired the well must be disinfected with a disinfectant solution equivalent to 50 ppm chlorine solution (See Table 2), unless specifically waived in writing by the landowner. The waiver must be worded in accordance with Attachment 1, "Waiver of Disinfection." The water well contractor/pump installation contractor must supply the landowner with an informational brochure that tells the owner why s/he should test his/her water and what the results mean.

12-011.01C Secure Cover: Any water well which is being serviced or repaired must be protected with a secure cover or cap during periods when the water well is left unattended.

12-011.01D Packaging of thread compounds, sealants, and lubricants must bear the NSF Standard 61 stamp of approval.

12-011.01E New Electrical Installations: When designing and installing a new water supply system, the electrical components must comply with the state electrical code. Electrical work that does not appear to meet standards may be reported to the State Electrical Board.

12-011.01F Repair or Modifications to Pumps and Pumping Equipment: Upon the removal of, or the repair and/or modification to the pump or pumping equipment in which replacement of original equipment is required, current pump and pumping equipment installation standards must be followed. This includes replacement of, or modification to the electrical wiring and/or controls located in the electrical layout serving the pump and pumping equipment including connection to the load side of the service disconnect or breaker. Any upgrade of this electrical system must be in compliance with all current applicable state or national electrical codes, and be installed according to the manufacturer's specifications.

12-011.01G Casing Vent: If a vent is used, it must terminate in a down-turned position, at or above the top of the casing or pitless unit and be covered with a 24 mesh corrosion-resistant screen.

12-011.02 Installation of Pumps: All pump installation must comply with 178 NAC 12-011.01 and 12-011.03.

12-011.02A Line Shaft Pumps must be equipped with a pump base and be designed so the weight of the pump and column pipe is supported by the casing or is resting on a concrete platform which rests upon natural ground and they must be secured to prevent movement.

12-011.02B Submersible Pumps: The drop pipe must be steel pipe, NSF 61 approved plastic material, or fiberglass. There must be at least 1 check valve within the casing which may be furnished with the pump.

12-011.02C Centrifugal and Jet Pumps do not require a relief valve. They must be equipped in the following manner:

1. Offset Location: The suction pipe must be encased in a sleeve from the basement or well pit wall to the well. In the instance of a packer jet system, the pressured pipeline can serve as a sleeve for the suction line.
2. Priming Port must be located higher than the discharge of the pump. Discharge of the priming port may be controlled with a shut off valve. Potable water must be used for priming the pump. Priming valve must be sealed when not in use to prevent contamination from accumulating above the valve.

12-011.02D Reciprocating Pumps must be equipped with a pump base. The pump base must be designed so the weight of the pump pipe and cylinder is supported by steel casing or a metal sleeve embedded in concrete. It must be secured to prevent movement.

12-011.03 Installation of Pumping Equipment

12-011.03A Pitless Units must:

1. Bear the Pitless Adapter Standard (PAS) stamp of approval of the Water Systems Council.
2. Be factory assembled and ready for installation from a point of connection with the well casing to the unit cap or cover.
3. Be a threaded, welded, screwed, or flanged gasket compression connection to the well casing.
4. Be of watertight construction throughout, except for any required vent.
5. Be made of steel through the frost zone and be compatible with the casing.
6. Have a field connection to the lateral discharge from the pitless unit of threaded, flanged, or mechanical joint connection.
7. Terminate at least 12 inches above final ground elevation. Where a water well needs to be located in an area of high traffic and physical damage to the pitless unit is probable, the contractor must finish off the

water well even with the grade of the surrounding land surface and protect it by terminating it in a pitless unit covered by a watertight flush mount cover capable of withstanding high vehicle traffic conditions. In all cases where the top of the pitless unit is enclosed in a watertight flush mount vault, the vent opening must be sealed and all electrical conduit fittings must be watertight. If the entrance of the electrical conduit is below ground level, the opening around the wire must be sealed. (See Figure 12)

8. Provide:
 - a. Access to the well for disinfecting or other purposes;
 - b. A properly constructed vent for wells with a pumping rate greater than 50 gpm;
 - c. A watertight secure cover at the upper terminal of the well that will prevent the entrance of contamination;
 - d. A contamination-proof entrance connection for electrical cable; and
 - e. An inside diameter sufficient for the insertion and removal of the pump and pumping equipment.

12-011.03B Pressure Relief Valve must be installed on any pump capable of developing a pressure higher than 115 psi, or exceeding the safe working pressure rating of the water supply system. Relief valve must be of adequate size and the plumbing where the relief valve is located must have sufficient capacity to accommodate 50% of the rated pump volume.

12-011.03C Backflow Protection: The discharge piping from any pump and pumping equipment must be equipped with a backflow preventer. A backflow preventer must be placed before any other device or branches in the distribution piping. Check valves must not be buried at the well for backflow prevention. The device must be located within 1 foot of the discharge head and prior to any other devices.

12-011.03D Discharge Piping includes any and all piping beginning at the discharge head or pitless unit tapping, extending to the first shut off valve or backflow preventer.

12-011.03D1 Above ground discharge piping must:

1. Be protected against the entrance of contamination;
2. For potable water use, be constructed of materials appropriate to each specific service;
3. Be equipped with a backflow preventer, chemigation valve, or air gap;
4. For air gap protection, daylight above the high water line of any tank, pond, stream, or reservoir;

5. Be properly anchored to prevent movement; and
6. Be protected against water hammer.

12-011.03D2 Underground Discharge Piping must be equipped with a curb stop valve and schedule 80 plastic or metal riser within one foot of the discharge, and be in compliance with 178 NAC 12-011.01.

12-011.03E Sample Point: Distribution piping must include a sample point. Location of the sample point must be as follows:

1. Sample point must terminate no less than 12 inches above the floor of the basement, well pit, or pump house floor.
2. A primary sample point must not be located down flow from any filter, trap, or conditioning equipment. A secondary sample point may be located down flow from a filter, trap, or conditioning equipment to verify the proper operation of such equipment.

12-011.03F Storage Tanks

1. Pressurized, if used (hydro-pneumatic or captive-air design)
 - a. Tank construction must be of materials approved for use in potable water systems; and
 - b. Tanks must be equipped with identification as to size, maximum working pressure, and name of manufacturer; and
 - c. Tanks and combinations of tanks and mechanical or electronic short cycle prevention devices must be of adequate size and design to prevent short cycling of the pump motor as per the pump motor manufacturer's specifications.
2. Non Pressurized, if used (reservoirs, cisterns, and standpipes)
 - a. Underground storage tanks must be constructed of material that is structurally adequate to withstand being buried below ground surface without collapsing when emptied;
 - b. Vent must be turned downward and be covered with a #24 mesh screen;
 - c. Vent piping must be of adequate size to prevent either a positive or negative pressurization of the buried tank, and
 - d. Vent piping must be constructed of materials approved for use in potable water systems. Inspection hatch and vent must extend 12 inches above grade. Inspection hatch must have a watertight seal to prevent contaminants from entering the tank.

12-011.03G Above Ground Connections: A pump house may be utilized to prevent the freezing of pipes. If used, the pump house must be mounted on a concrete

platform which slopes away from the well in all directions. The casing must extend a minimum of 12 inches above the concrete platform and the space between the casing and the pump pipe must be closed with a sanitary well seal. The well seal must be watertight and if vented, must be provided with a screened vent.

12-011.03H Well Pit: The installation of pumping and storage equipment in a pit directly over a well is not allowed. A pit for housing the equipment must be located at least 10 feet away from a well.

12-012 WATER WELL DECOMMISSIONING

12-012.01 General Requirements: The well cavity of all water wells to be decommissioned must be filled and sealed in accordance with the appropriate procedure described below. Any licensed water well contractor constructing a water well for any customer must as a part of the agreement include the proper decommissioning of each water well and test hole constructed to explore for ground water pursuant to the agreement. A landowner may only decommission a driven sandpoint water well on land owned by him/her and used by him/her for farming, ranching, or agricultural purposes or as his/her place of abode. A well constructed after October 1, 1988, but not constructed according to Title 178 NAC 12 must have a Declaratory Order prior to decommissioning.

12-012.02 Preliminary Work: Prior to decommissioning a water well, the depth of the well and the static water level must be measured and an investigation must be made to determine the details of the well construction. Potential sources of well construction details include:

1. The personal records of the owner,
2. The contractor that drilled the well,
3. The registration forms on file with the Nebraska Department of Natural Resources, available on its website,
4. Water well contractors familiar with the area, and
5. Water well records on file with the University of Nebraska-Lincoln Conservation and Survey Division, School of Natural Resources.

12-012.03 Obstructions: Every effort must be made to remove obstructions. If they cannot be removed, the well cavity must be filled with approved fill material in accordance with 178 NAC 12-003.08B from the bottom of the well to a point above the obstruction. If this is not possible, a 5-foot non-slurry bentonite grout plug must be placed above the obstruction, or the entire length of the water well from the obstruction to the surface must be grouted.

12-012.04 Material Volume: The volume of material required to decommission a water well can be determined using Table 3. Volumes for each interval that is to be either filled or sealed must be calculated prior to beginning. Materials used and calculated volumes must be consistent. If they are not, (1) additional material must be added to replace lost volumes until the interval is filled or sealed or (2) if material bridges in the well (evidenced

by calculated amount of filler/sealer being too much), operations must stop until the bridge is removed by high pressure jetting, drilling, or other methods.

12-012.05 Well Decommissioning Materials: Approved fill material (178 NAC 12-003.08B, 12-012.05B) or grout material (178 NAC 12-012.05A) must be used to decommission water wells. Grout seals must be used to prevent water movement into or between water-bearing zones; approved fill material may be used where grout seals are not necessary.

12-012.05A Grout Material: Grout material found in 178 NAC 12-003.06 can be used as a seal in decommissioning water wells.

12-012.05B Approved Fill Material for Decommissioning to be used in water wells in intervals where grout seals are not used or are not required must be disinfected sand, gravel, or crushed stone except that native earth material may be used in large diameter bored or dug wells because of the volume required. All fill material must be free of potentially toxic chemical residue and trash such as leaves and foreign materials. All fill material must be sized and introduced into the well at a rate to avoid bridging.

12-012.06 Decontaminating: Disinfectant equivalent to at least 200 parts per million chlorine must be introduced into the well before any material is placed into the well. The disinfectant can be in a liquid, granular, or pellet form. This will also decontaminate the fill material placed adjacent to the water-bearing zones. (See Table 1 for the amount of disinfectant to use.)

12-012.07 Upper Plug: All cased water wells to be decommissioned must have an upper plug to prevent surface and near-surface contaminants from entering the well casing. Only non-slurry bentonite and sand cement grouts are allowed in the upper plug. If the water well records indicate that a surface seal was installed during construction, then any option below can be used. If a surface seal was not installed or it is not known if a surface seal was installed, then Option 1 or Option 3 must be used.

12-012.07A Option 1: Remove the top 3 feet of the well casing and grout the upper 5 feet of the remaining casing. Install a 6-inch thick grout seal above the top of the casing that extends a minimum of 1 foot past the walls of the original borehole and extends at least 1 foot below the top of the cut-off casing. Backfill the remainder of the hole with native soil mounded for settlement and proper drainage. (See Figure 13)

12-012.07B Option 2: For all other wells not located in a structure and if the water well was constructed with an annular surface seal, the water well casing may be left in place. A 5-foot long grout plug must be placed in the casing within the top 10 feet. If the casing is going to remain above the concrete surface, a watertight secure cover or cap must be installed on top of the casing. (See Figure 14)

12-012.07C Option 3: If the water well is surrounded by concrete/asphalt that extends 1 foot beyond the original borehole, and the casing is to be cut off flush with the top of the concrete, then a 5 foot minimum grout plug must be placed 10 feet below the concrete pad, and a minimum of 5 feet of concrete must be installed above the grout plug and struck off level with the top of the concrete. (See Figure 15)

12-012.08 Procedures for Specific Well Types are set forth below and must be followed.

12-012.08A Test Holes must be sealed with a 5-foot grout plug placed at static water level and/or confining layer. Approved fill material must be placed from the 5 foot grout plug to the surface seal within the top 10 feet.

12-012.08B Drilled, Bored, or Dug Water Wells

1. Measure the static water level and the total depth of the well.
2. If there is no water in the casing, place a minimum 5 foot grout plug in the bottom as described in the Placement of Grout section (178 NAC 12-003.07).
3. Use these measurements and the information in Tables 3 and 4 to determine the volume of material to be used.
4. Fill the well cavity or casing with clean disinfected sand, gravel, or grout up to 1 foot below the static water level.
 - a. If the static water level is less than 6 feet, refer to upper plug procedures for near-surface decommissioning.
 - b. If the static water level is greater than 6 feet, place a seal at least 5 feet thick on top of the sand/gravel fill. (See Figure 16.)
5. Native earth is an acceptable decommissioning fill material only for dug or bored wells that are two feet or more in diameter because of the volume required. Place native earth material in the excavated hole and mound over the well to accommodate future settling and to divert surface water away from the well. (See Figure 17)
6. Fill the remainder of the well with clean sand or gravel or grout up to 8 feet below the ground surface. At this point, place a 5-foot non-slurry bentonite grout seal in the casing. (See Figure 17)
7. The remainder of the water well must be decommissioned as described in the Plug Section. (See Figure 13)

12-012.08C Driven Sandpoint Wells

1. Fill the entire casing with grout to the top and cut off the casing 3 feet below the ground surface or water level. Place a 6-inch grout seal 1 foot beyond the casing and backfill the remainder of the hole with native soil mounded for settlement. (See Figure 18) or
2. If the casing is pulled, decommission like a test hole as described in 178 NAC 12-012.08A.

12-012.08D Full Length Grouted Wells must be decommissioned by pressure grouting the inside of the screen and casing. (See Figure 19) The rest of the well must be decommissioned as described in the Upper Plug Section, Option 1 or Option 3 only, as described in 178 NAC 12-012.07A and 12-012.07C.

12-012.08E Multiple Aquifer Wells: Water wells that obtained water from more than 1 water bearing zone must have a seal between each zone if each water bearing zone is separated by a confining layer. (See Figure 20) A grout seal not less than 5 feet in length must be placed adjacent to each confining layer and 5 feet of grout must be placed at the static water level.

12-012.08F Flowing Water Wells: Decommissioning these wells requires the placement of neat cement through a tremie line to stop the flow; otherwise, expandable plugs may be installed in the casing (or bedrock if not cased) to stop the water flow.

12-012.08F1 If it is known where a confining layer exists, the following procedure to install an intermediate seal (see Figure 21) is required.

12-012.08F1a If, during construction, the annular space was not grouted at the confining unit, a plug must be set at the bottom of the confining layer and the casing must be perforated a minimum of 3 feet, to allow pressure grouting of the annular space with neat cement.

12-012.08F1b Bentonite grout can be used above the confining layer if the flow has been stopped. The rest of the well must be decommissioned as described in the Upper Plug section, 178 NAC 12-012.07.

12-012.08F2 The exact location of these wells must be flagged for at least 1 year after decommissioning.

12-012.08G Closed Loop Heat Pump Wells must be decommissioned as follows:

1. Remove all heat transfer fluid from the closed loop, and

2. Dig down to the top of the borehole and cut off the loop pipe at least 6 feet below the surface. Pump the remaining loop full of bentonite or cement slurry. The remainder of the borehole is to be decommissioned as described in the Upper Plug section 178 NAC 12-012.07.

12-012.09 Documentation: A record that includes the materials used, the quantity of those materials, location of placement thereof, and mix specifications, including the type and viscosity of bentonite grouts must be maintained on every decommissioned water well, including test holes.

12-012.10 Reporting Decommissioning: A notice of decommissioning for all water wells except test holes must be submitted to the Director of the Department of Natural Resources on the Notice of Decommissioning form supplied by the Department of Natural Resources within 60 days of the decommissioning of the water well as required in Neb. Rev. Stat. § 46-602 as follows:

1. The pump installation contractor or water well contractor must submit written notice of the decommissioning of a water well to the Department of Natural Resources.
2. If both a water well contractor and a pump installation contractor are involved in the decommissioning of a water well, the pump installation contractor must submit the notice of decommissioning to the Department of Natural Resources.
3. If a landowner decommissions a driven sandpoint water well on land owned by him/her and used by him/her for farming, ranching, or agricultural purposes or as his/her place of abode, the landowner must report the decommissioning to the Department of Natural Resources.

12-013 DECLARATORY ORDER ABOUT SUBSTANTIALLY EQUIVALENT PROCEDURE OR MATERIAL

12-013.01 Any water well contractor, pump installation contractor or any other individual carrying out activities subject to 178 NAC 12 who desires to carry out such work by a procedure inconsistent herewith or using materials other than herein prescribed but which the contractor or other individual believes to be substantially equivalent to the standards prescribed in 178 NAC 12 may request a declaratory order by the Department on whether the proposed procedure or material is substantially equivalent to the prescribed standards and may be used to comply with 178 NAC 12.

12-013.02 Such a request must be submitted in writing at least 10 days prior to the initiation of construction or alteration of the well(s) involved, unless good cause is shown for a shorter review period.

12-013.03 The request must include a description of the material(s) and/or construction procedure(s) proposed, identify the procedure or material required by the prescribed

standards and include proof of the alleged equivalency and such written arguments as are deemed appropriate by the requesting party.

12-013.04 Such request must be made generally in accordance with 184 NAC 2, Rules of Practice and Procedure of the Department for Declaratory Orders, but unless the requesting party at the time of the request demands a hearing thereon, the matter will be deemed submitted on the written request, attachments thereto, and facts of which the Department takes judicial notice.

12-013.05 Any order issued by the Department hereunder will be binding between the Department and the requesting party on the facts alleged unless it is altered or set aside by a court. The Department may in situations when the submission of a request 10 days in advance would result in an immediate environmental threat, significant economic hardship on or pose a health threat to the owner or other individuals, waive the 10 day review period.

12-014 VARIANCES: The Department may grant a variance from any rule, regulation, or standard adopted and promulgated by the Department relating to the construction of a water well upon proof by a licensed water well contractor or well owner that the enforcement of the rule, regulation, or standard would create an unreasonable hardship or be unreasonable, impractical, or not feasible under the circumstances. A variance is limited to the construction of a water well to replace an existing water well. A variance may only be requested after a declaratory order about substantially equivalent procedure or material has been requested and denied.

12-014.01 Procedures for Requesting a Variance: The party requesting the variance or renewing a variance must submit the variance request to the Department along with any applicable fee. The request for a variance must be submitted in writing at least 10 days prior to the planned initiation of construction of the well involved. Variances may only be granted in writing by the Department. All variance requests must contain the following:

1. The name, address, telephone number, and signature of the individual(s) requesting the variance;
2. The specific rule(s) for which the variance is requested (if more than 1 rule is affected then each must be listed);
3. The reason the rule(s) cannot be met, with supporting evidence;
4. The length of time for which the variance is requested
5. The alternative or protective measure that will be taken to assure a comparable degree of protection to health or environment;
6. Construction plans and specifications of the proposed water well with all the relevant and required information listed in 178 NAC 12-003.12A; and
7. A scaled map showing the location of the well in relation to property lines, structures, utilities, and contamination sources.

12-014.02 Variance Conditions: A variance may be under such terms and conditions and for such time as the Department may prescribe. The Department must notify the requesting party in writing of the decision to grant or deny the variance. If a variance is

granted, the notification must specify conditions or alternative measures imposed upon the variance, if any. If the variance is denied, the Department will specify the reasons for the denial.

12-014.03 Alternative Measures or Conditions: Alternative measures or conditions attached to a variance have the force and effect of the applicable regulation. If the alternative measure or condition attached to the variance is violated, the party may be enjoined from continuing such activities. The injunction may include an order to properly decommission the water well.

12-014.04 Renewal of a Variance: A request for a renewal of a variance must be submitted in writing to the Department within 30 days of the expiration date. A renewal request must contain the information in 178 NAC 12-014.01 (Procedures for Requesting a Variance). A variance may be renewed if the party continues to satisfy the criteria for granting the variance and demonstrates compliance with the alternative measures or conditions imposed at the time the original variance was approved.

TABLE 1
Decontamination Chart Calculator for Total System Volumes

Casing ID Inches	Gal/ft	Ft of H ₂ O	Standing Well Volume ¹ Feet	Total Treat. Volume ²	Total Decontam. Volume ³	200 ppm	200 ppm
						5% chlorine gallons ⁴	65% HCL oz. ⁴
4	.065	100	65	130	260	0.26	15.6
5	1.02	100	102	204	408	0.408	24.48
6	1.47	100	147	294	588	0.588	35.28

Casing ID Inches	Gal/ft	Ft of H ₂ O	Standing Well Volume ¹ Feet.	Total Treat. Volume ²	Total Decontam. Volume ³	200 ppm	200 ppm
						5% chlorine gallons ⁴	65% HCL oz. ⁴
8	2.61	100	261	391.5	1044	1.044	62.64
10	4.08	100	408	612	1632	1.632	97.92
12	5.87	100	587	880.5	2348	2.348	140.88
16	10.45	100	1045	1567.5	4180	4.18	250.8
24	23.51	100	2351	3526 .5	9404	9.404	564.24

¹Standing Well Volume equals the total amount of water in the casing.

²Total Treatment Volume equals the amount of water in the casing plus the annular space of the borehole.

1. For 4" to 6" wells, the standing well volume times 2 equals the total treatment volume.
2. For 8" wells and larger the standing well volume times 1.5 equals the total treatment volume.

³Total Decontamination Volume equals the standing volume times 4 to approximate the water in the system.

⁴The decontamination amounts are based on a calculation or percent of the available chlorine and dosage strength per given volume of water.

TABLE 2
Disinfection Chart Calculator for Total System Volumes

Casing ID Inches	Gal/ft	Ft of H ₂ O	Standing Well Volume ¹ Feet	Total Treat. Volume ²	Total Disinf. Volume ³	50 ppm	50 ppm
						5% chlorine gallons ⁴	65% HCL oz. ⁴
4	.065	100	65	130	260	0.065	3.9
5	1.02	100	102	204	408	0.102	6.12
6	1.47	100	147	294	588	0.147	8.82

Casing ID Inches	Gal/ft	Ft of H ₂ O	Standing Well Volume ¹ Feet.	Total Treat. Volume ²	Total Disinf. Volume ³	50 ppm	50 ppm
						5% chlorine gallons ⁴	65% HCL oz. ⁴
8	2.61	100	261	391.5	1044	0.261	15.66
10	4.08	100	408	612	1632	0.408	24.48
12	5.87	100	587	880.5	2348	0.587	35.22
16	10.45	100	1045	1567.5	4180	1.045	62.7
24	23.51	100	2351	3526.5	9404	2.351	141.06

¹Standing Well Volume equals the total amount of water in the casing.

²Total Treatment Volume equals the amount of water in the casing plus the annular space of the borehole.

1. For 4" to 6" wells, the standing well volume times 2 equals the total treatment volume.
2. For 8" wells and larger the standing well volume times 1.5 equals the total treatment volume.

³Total Disinfection Volume equals the standing volume times 4 to approximate the water in the system.

⁴The disinfection amounts are based on a calculation or percent of the available chlorine and dosage strength per given volume of water.

Table 3
Well casing volume and bentonite needed to fill a well casing

Diameter of opening	Volume		Approximate pounds graded bentonite per foot*	Approximate linear feet filled per 50 pound bag of graded bentonite
	Gallons per foot of depth	Cubic feet per foot		
2 inches	0.16	0.02	1.4	35.70
3 inches	0.37	0.05	3.5	14.30
4 inches	0.65	0.09	6.3	7.90
5 inches	1.02	0.14	9.8	5.10
6 inches	1.47	0.20	14.0	3.60
8 inches	2.61	0.35	24.5	2.00
10 inches	4.08	.055	38.5	1.30
12 inches	5.88	0.79	55.3	0.90
14 inches	8.00	1.07	74.9	0.67
16 inches	10.44	1.40	98.0	0.51
18 inches	13.22	1.77	123.9	0.40
2 feet	23.50	3.14	220.0	0.23
2.5 feet	36.72	4.91	344.0	0.16
3 feet	52.88	7.07	495.0	0.10
4 feet	94.00	12.57	880.0	0.06
5 feet	146.90	19.64	1375.0	0.04
6 feet	211.50	28.27	1979.0	0.03
7 feet	287.90	38.48	2694.0	0.02
8 feet	376.00	50.27	3519.0	0.01
9 feet	475.90	63.62	4453.0	0.01
10 feet	587.50	78.54	5498.0	0.01

*Based on a granular bentonite bulk density of 70 pounds per cubic foot. (The typical range of reported bulk density is 68 to 72 pounds per cubic foot)

Table 4

Useful Equivalents	
1 cup	8 fluid ounces
2 cups	1 pint
1 pint	16 fluid ounces
1 quart	32 fluid ounces
½ gallon	64 fluid ounces
1 gallon	128 fluid ounces
1 cubic foot (ft ³)	7.48 gallons
1 cubic yard (yd ³)	27 cubic feet
Gallons per foot of depth	0.0408 (opening diameter, square inches)
Cubic feet per foot of depth	0.0055 (opening diameter, square inches)
1° Latitude	69.2 miles
1 minute of 1°	6,089.6 feet
1 second of 1 minute of 1°	101.49333 feet
1/10 of 1 second of 1 minute of 1°	10.149333 feet
1° Longitude	69.172 miles
1 minute of 1°	6,087.136 feet
1 second of 1 minute of 1°	101.45226 feet
1/10 of 1 second of 1 minute of 1°	10.145226 feet

EFFECTIVE
8/26/14

NEBRASKA DEPARTMENT OF
HEALTH AND HUMAN SERVICES

178 NAC 12
ATTACHMENT 1

WAIVER OF DISINFECTION

This is to certify that I have been informed by _____
of the advantages of the disinfection of the water well producing water for human consumption
located at _____.

I do not desire to have the well disinfected and hereby waive the disinfection requirement.

Landowner or Owner's Agent

Date

**FIGURE 1A.
PRIMARY AQUIFER SEAL ON TOP OF
GRAVEL PACK ABOVE THE WELL SCREEN**

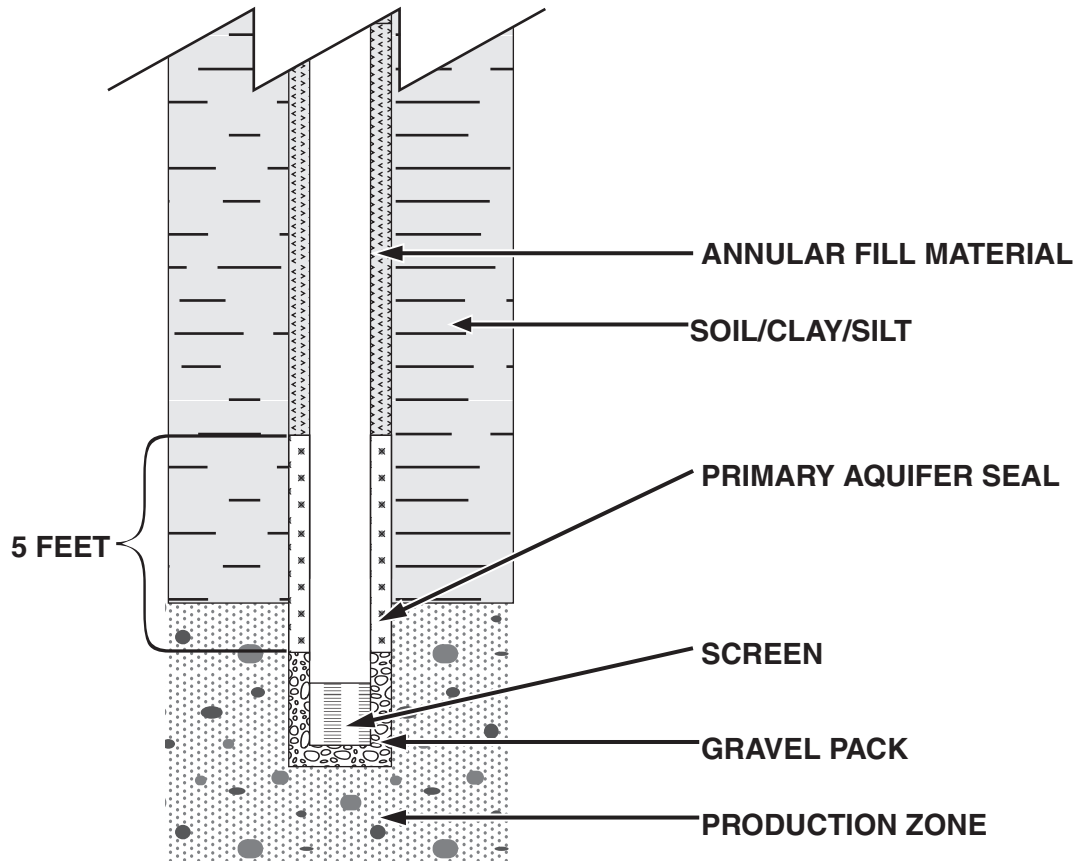

This figure is only for illustrative purposes of the referenced regulation. See the regulation text for the complete standard requirements.

**FIGURE 1B.
PRIMARY AQUIFER SEAL AT THE BASE OF THE
FIRST SILT/CLAY LAYER ABOVE THE PRODUCTION ZONE**

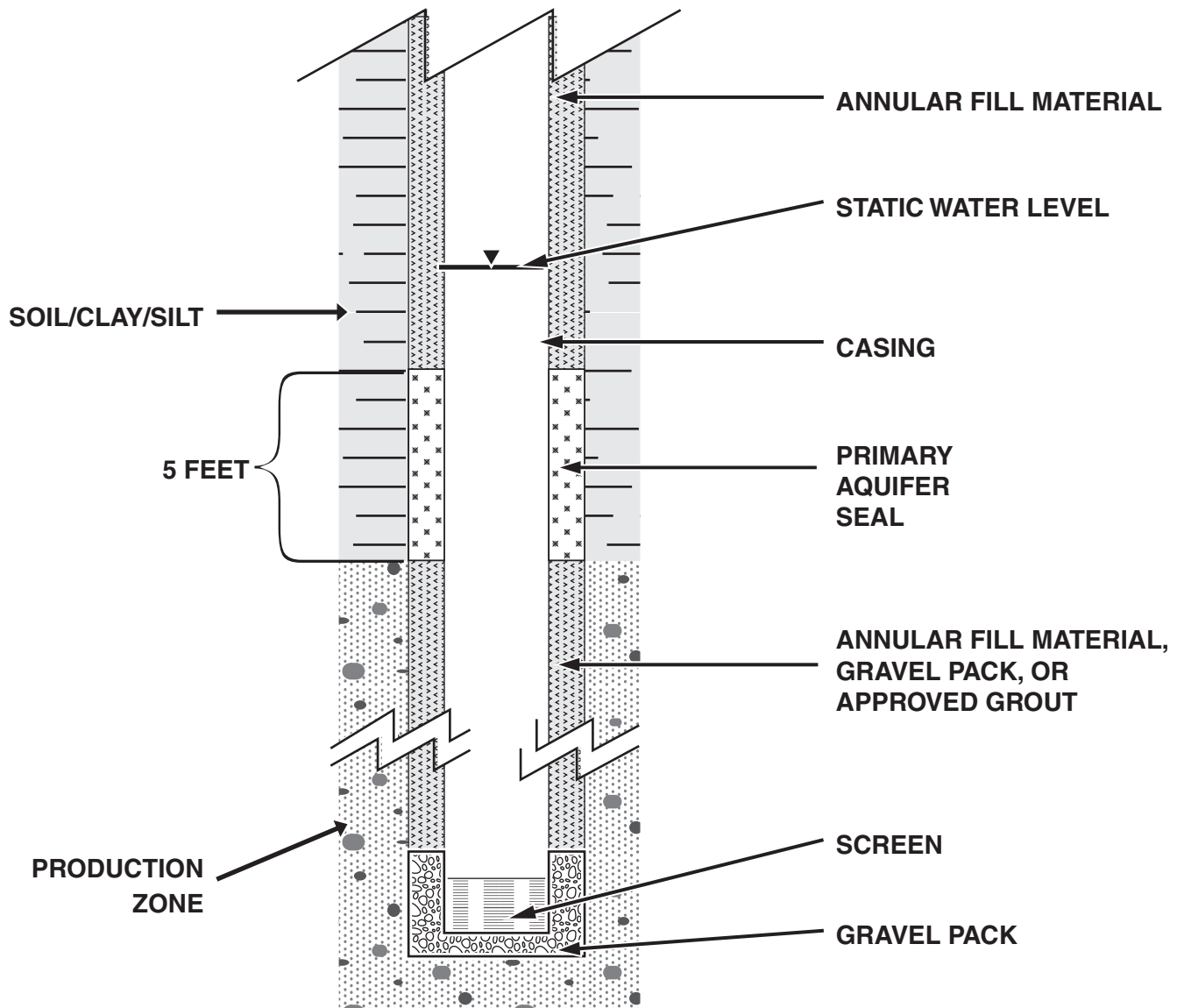

This figure is only for illustrative purposes of the referenced regulation. See the regulation text for the complete standard requirements.

**FIGURE 1C.
PRIMARY AQUIFER SEAL AT/OR IMMEDIATELY
BELOW THE STATIC WATER LEVEL**

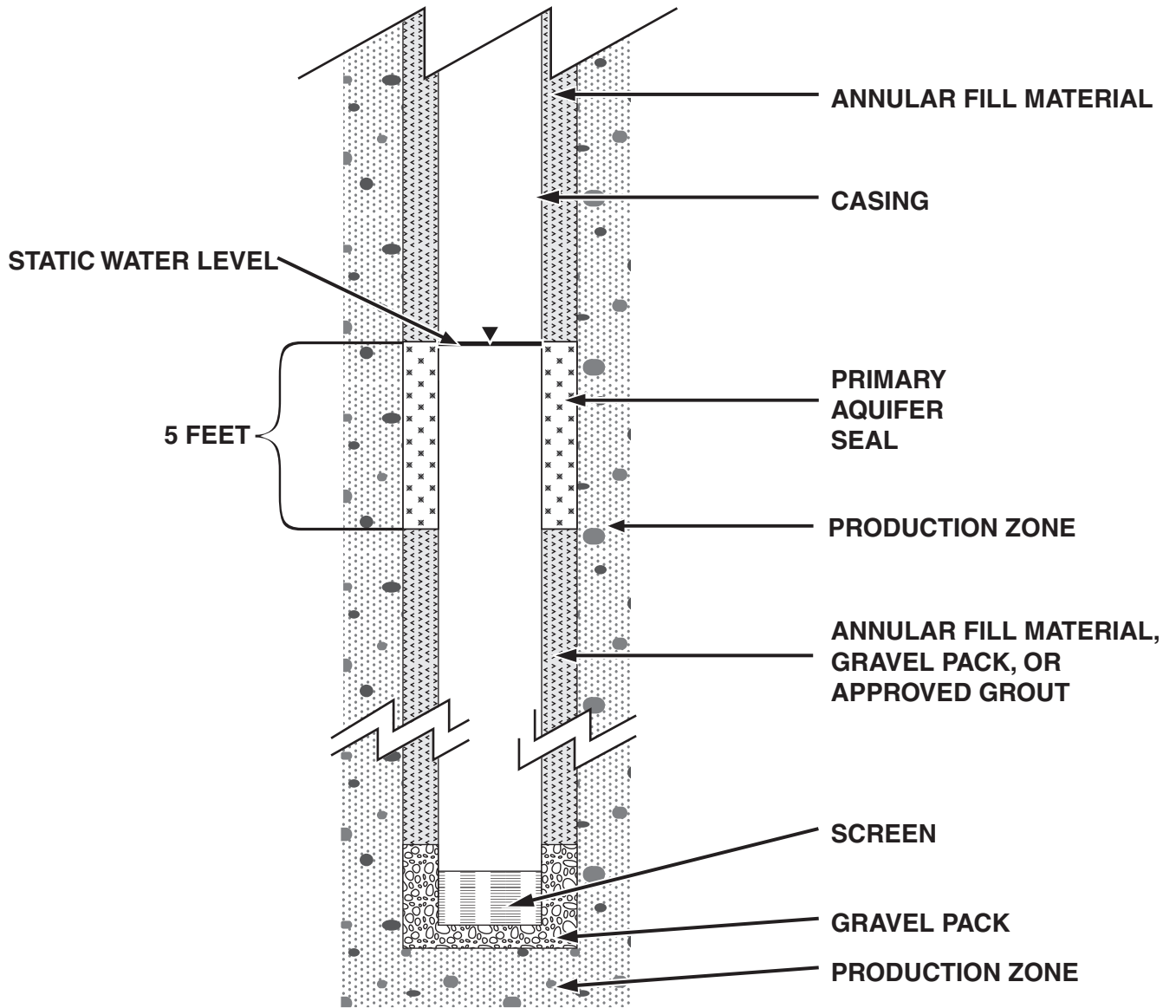

This figure is only for illustrative purposes of the referenced regulation. See the regulation text for the complete standard requirements.

**FIGURE 2A.
SURFACE SEAL FOR ALL WELLS NOT
EQUIPPED WITH PITLESS UNITS**

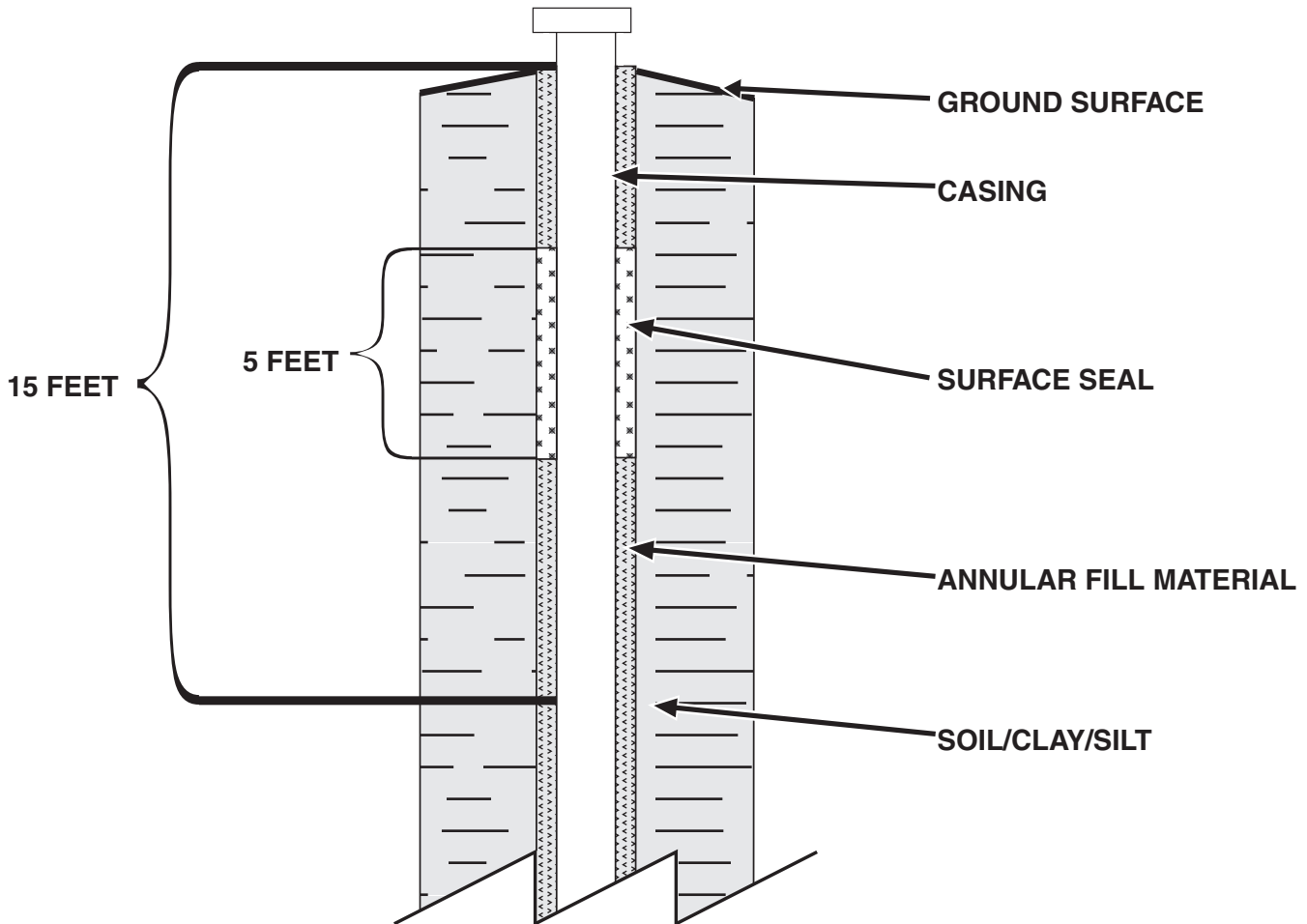

This figure is only for illustrative purposes of the referenced regulation. See the regulation text for the complete standard requirements.

**FIGURE 2B.
SURFACE SEALS FOR ALL
WELLS WITH PITLESS UNITS**

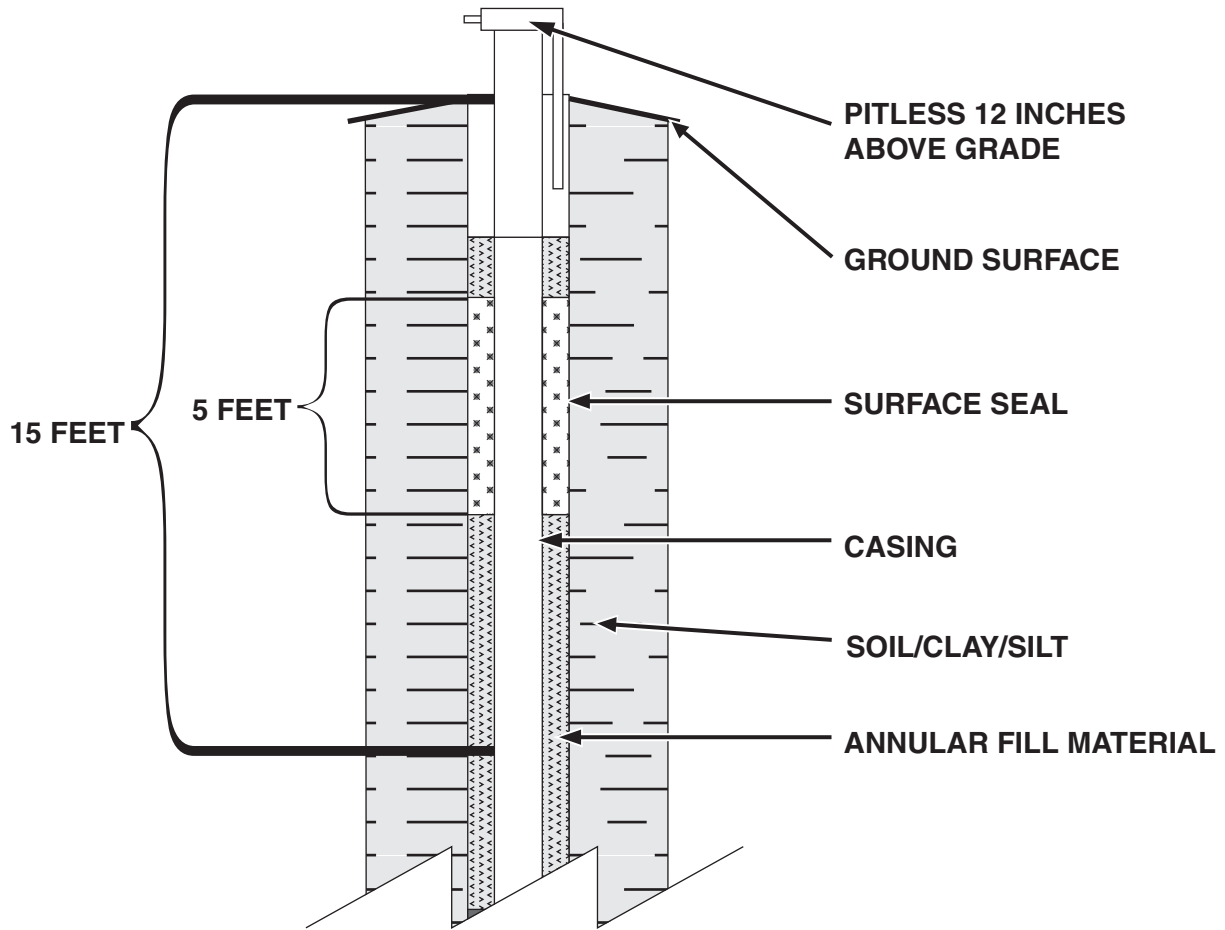

This figure is only for illustrative purposes of the referenced regulation. See the regulation text for the complete standard requirements.

**FIGURE 3.
CONSTRUCTION AND REPAIRS OF BORED
AND DUG WELLS**

178 NAC 12-003.11
12-004.04
12-005.03

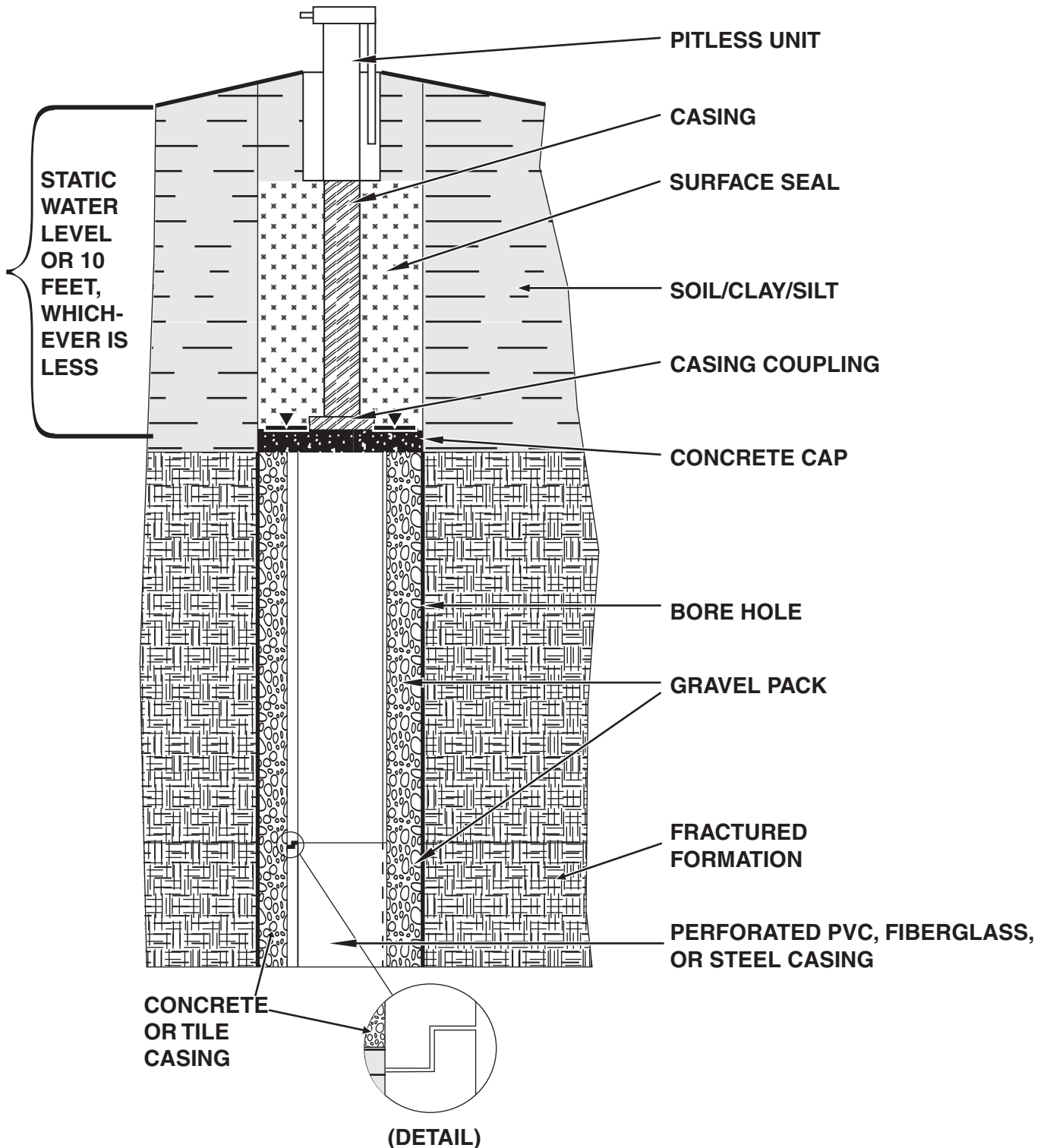

This figure is only for illustrative purposes of the referenced regulation. See the regulation text for the complete standard requirements.

**FIGURE 4.
OPEN HOLE WELL CONSTRUCTION**

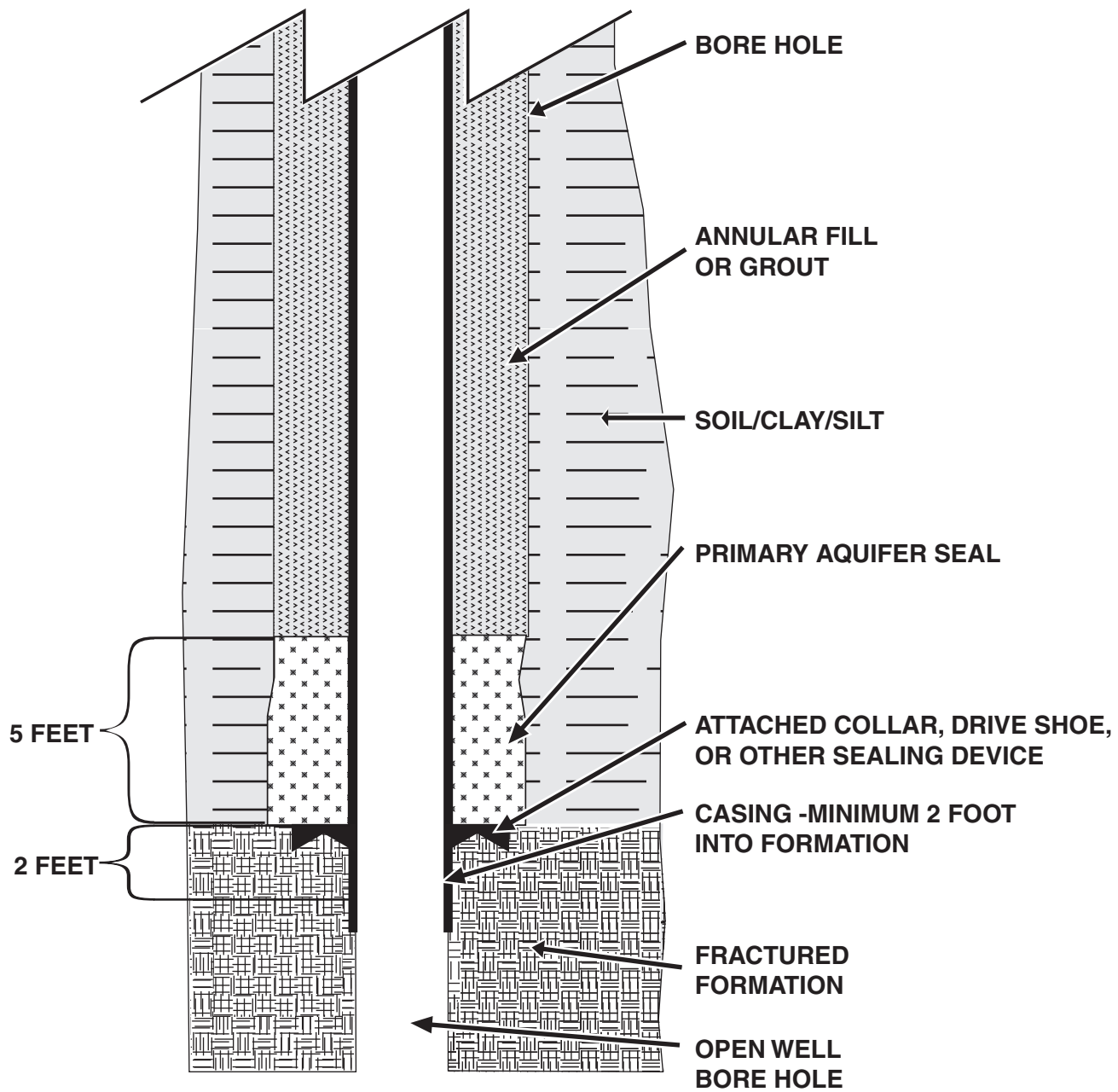

This figure is only for illustrative purposes of the referenced regulation. See the regulation text for the complete standard requirements.

**FIGURE 5.
OPEN HOLE CONSTRUCTION - MULTIPLE AQUIFERS**

178 NAC 12-004.05C
12-005.04C

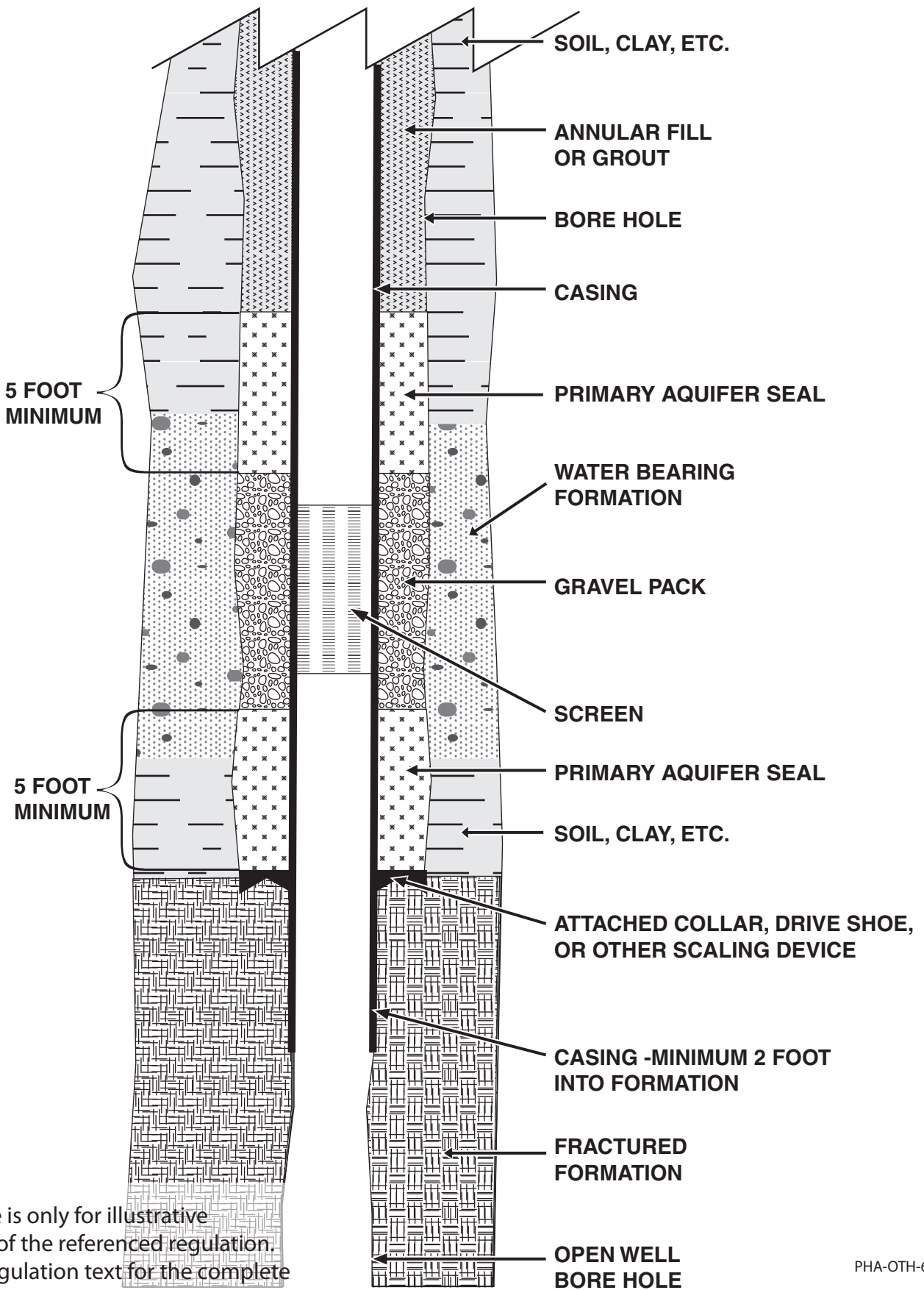

This figure is only for illustrative purposes of the referenced regulation. See the regulation text for the complete standard requirements.

FIGURE 6.
UPPER PORTION OF NON-POTABLE WELLS 6-5/8 INCH
OD AND LESS WITH STEEL CASING RISER

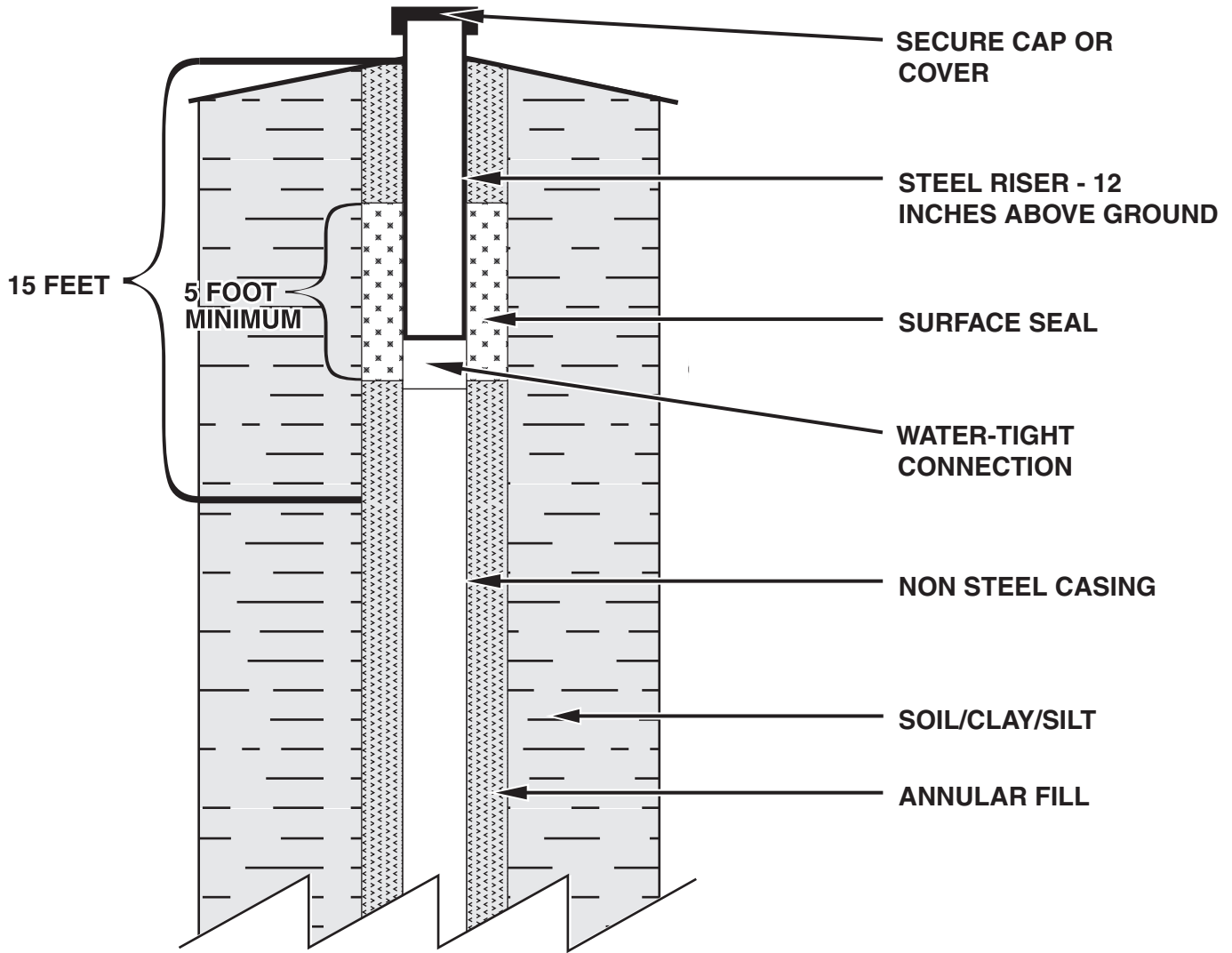

This figure is only for illustrative purposes of the referenced regulation. See the regulation text for the complete standard requirements.

**FIGURE 7.
NON-POTABLE WELLS 6-5/8 INCH OD AND LESS
WITH METAL SLEEVE BOLLARD**

178 NAC 12-005.02A2

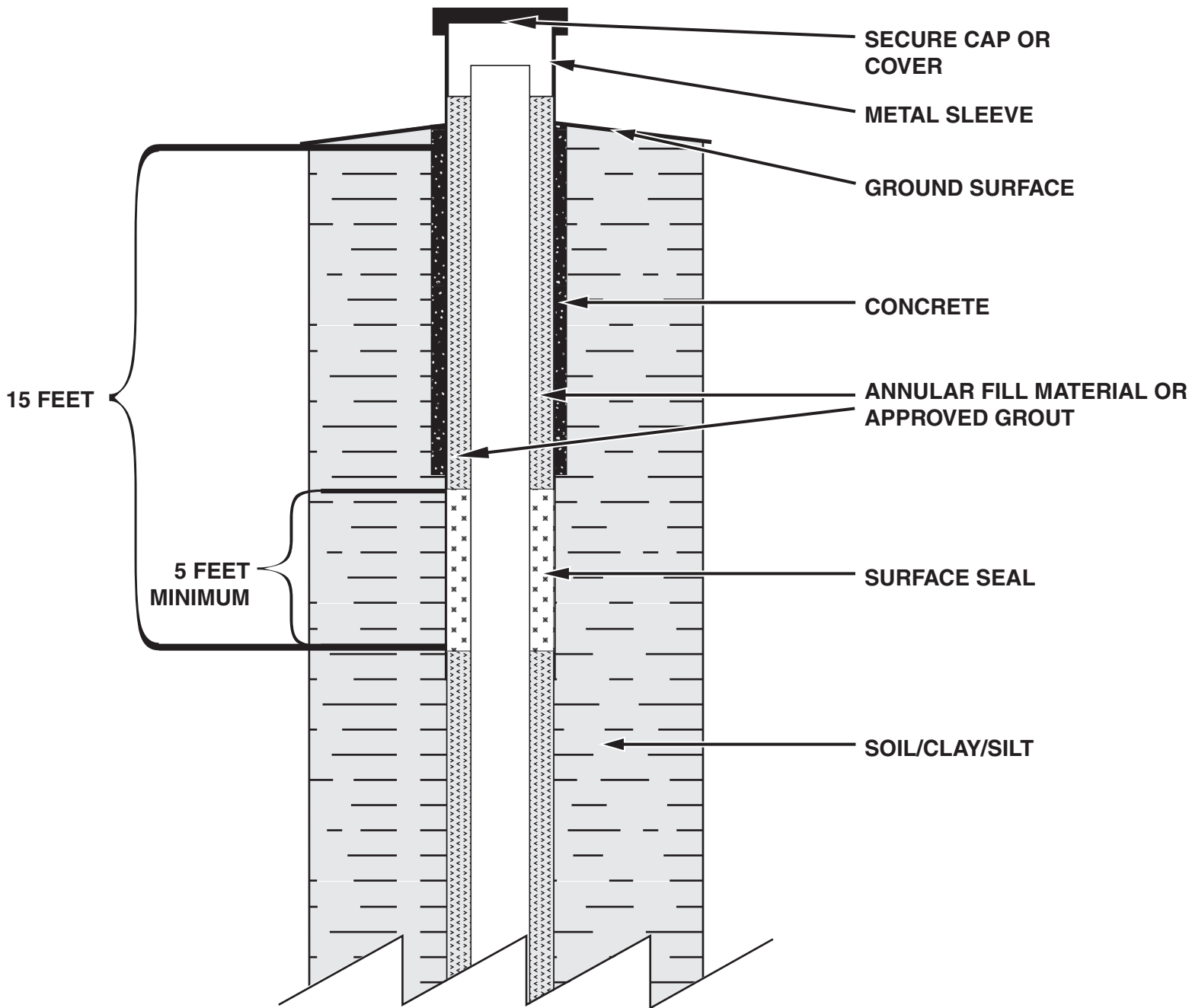

This figure is only for illustrative purposes of the referenced regulation. See the regulation text for the complete standard requirements.

**FIGURE 8.
CONCRETE PAD FOR NON-POTABLE WELLS
LARGER THAN 6-5/8 INCHES IN OD**

178 NAC 12-005.02B1
12-005.02B2
12-005.02C

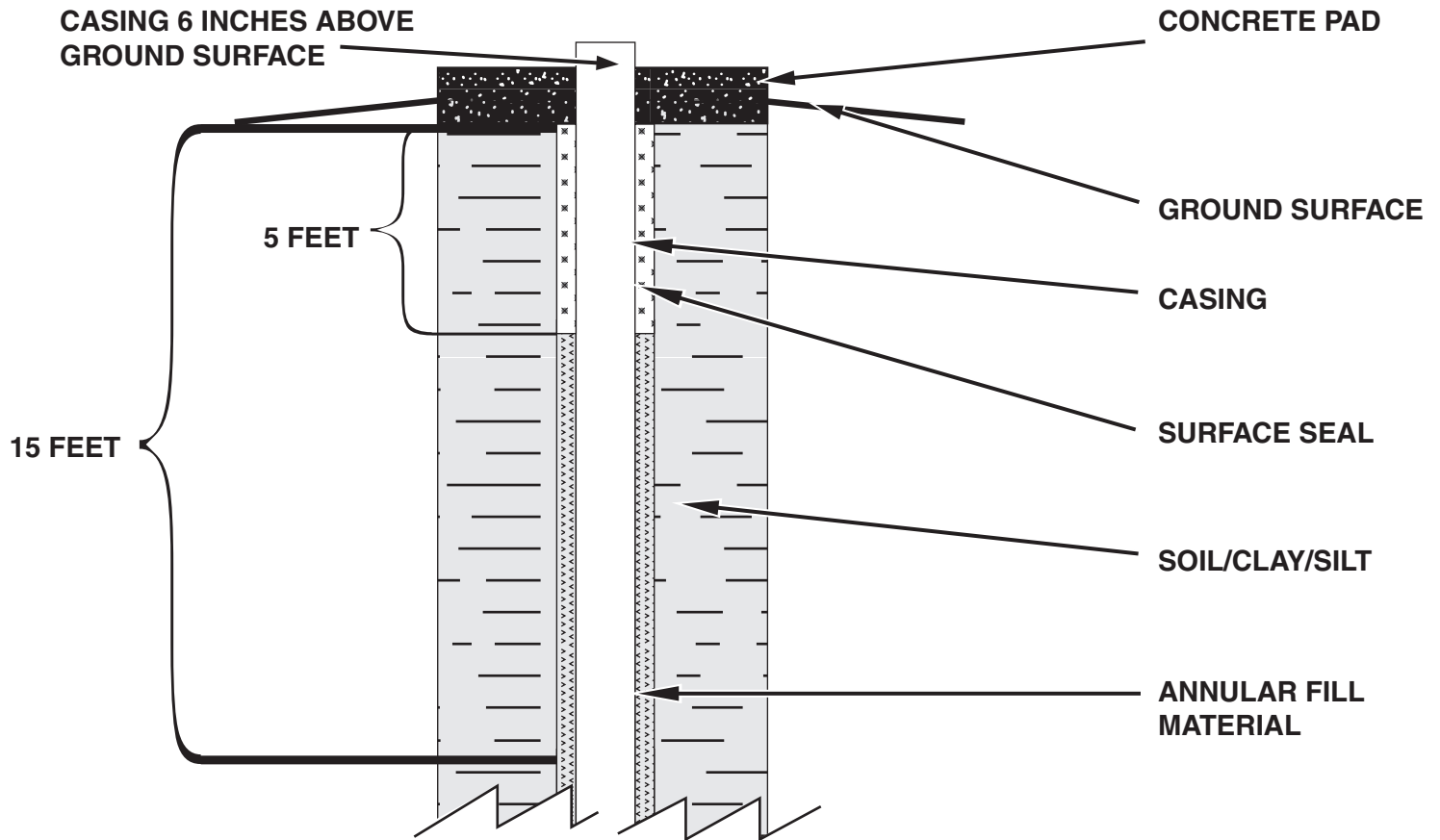

This figure is only for illustrative purposes of the referenced regulation. See the regulation text for the complete standard requirements.

**FIGURE 9
WELLS LOCATED IN THE ARIKAREE FORMATION
THAT ARE SUBJECT TO SUBSIDENCE**

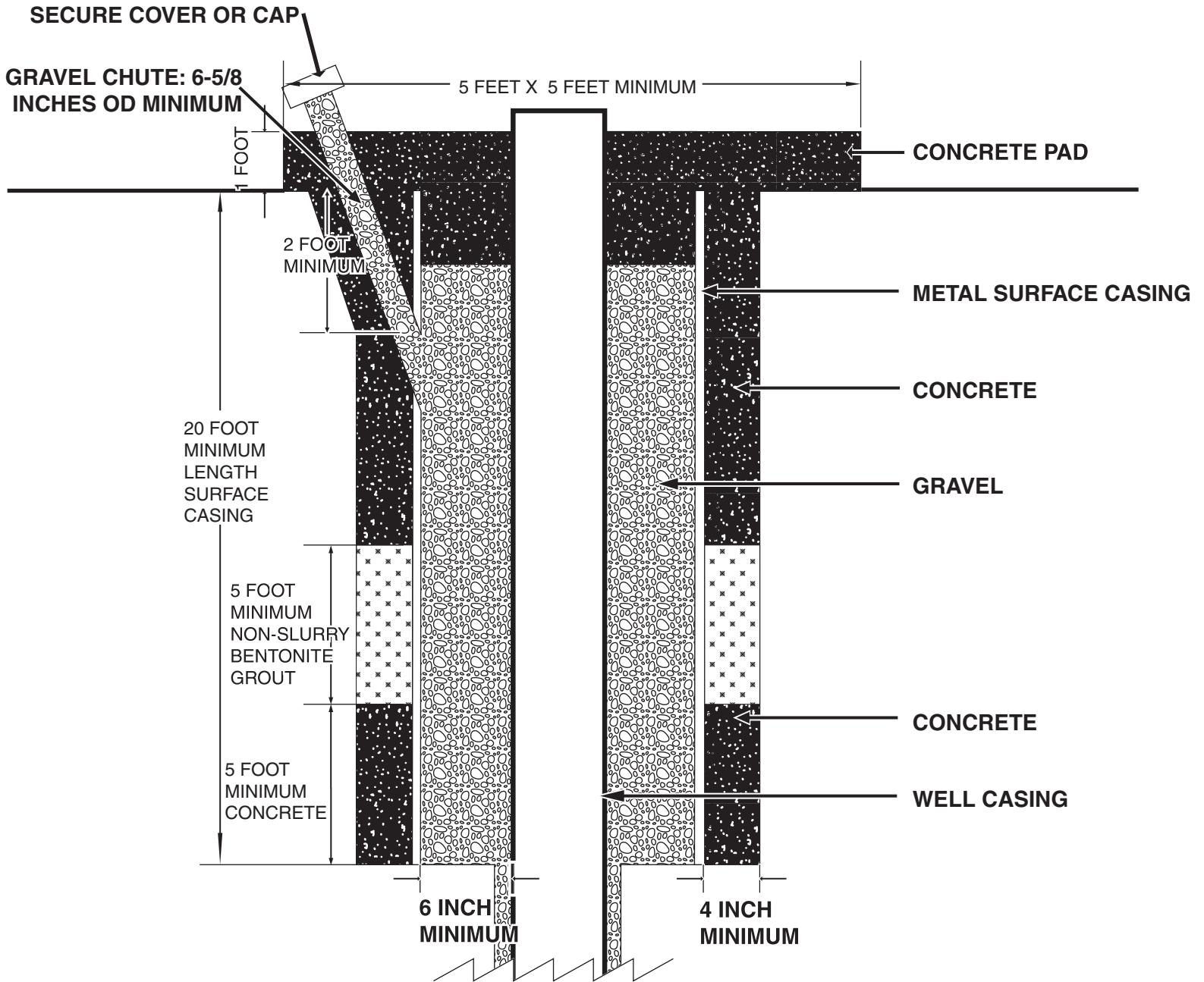

This figure is only for illustrative purposes of the referenced regulation. See the regulation text for the complete standard requirements.

**FIGURE 10
NESTED WELL DESIGN**

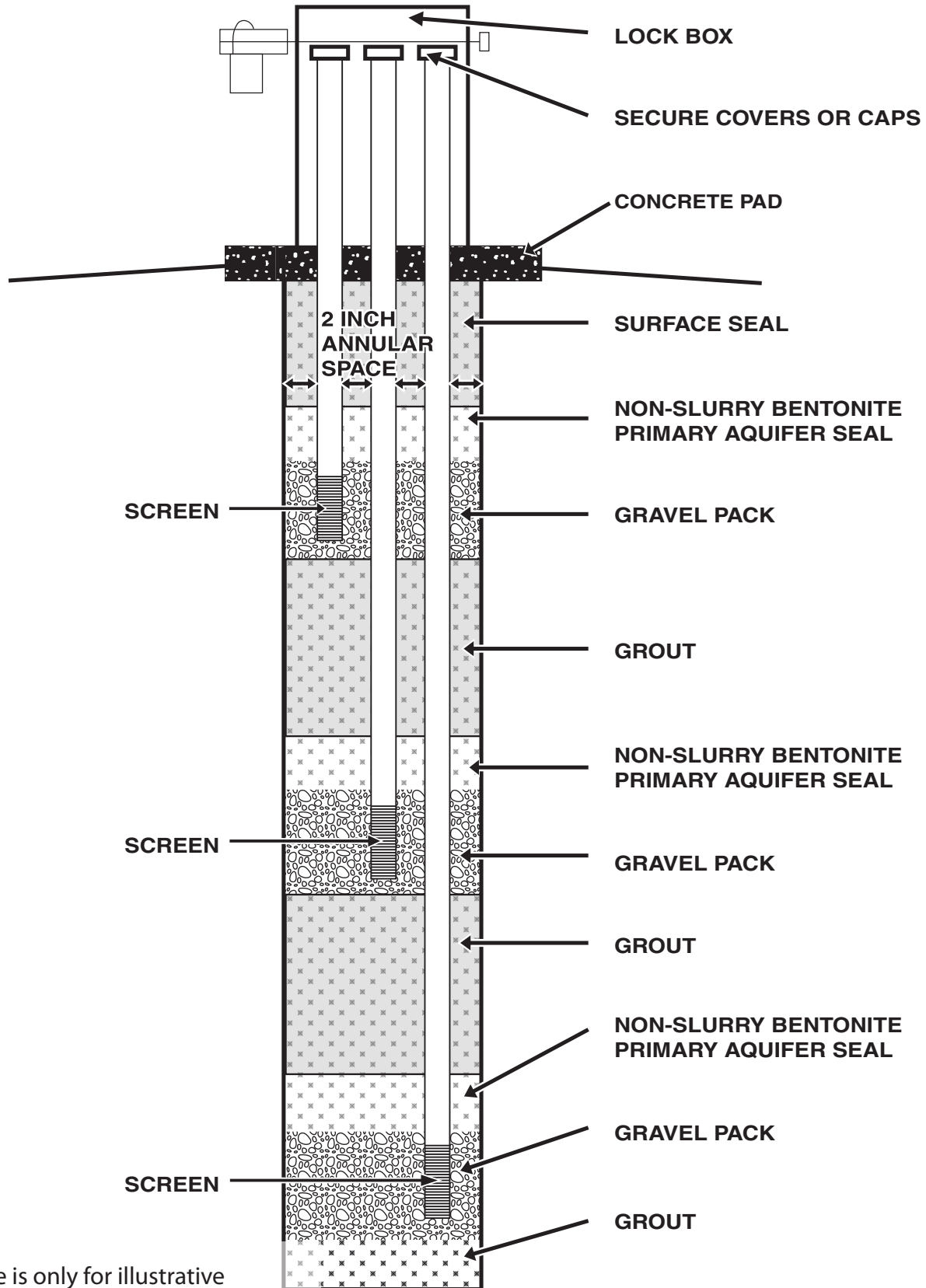

This figure is only for illustrative purposes of the referenced regulation. See the regulation text for the complete standard requirements.

**FIGURE 11A.
CLOSED LOOP WATER WELL AS PER 46-1212
10 OR MORE BOREHOLES**

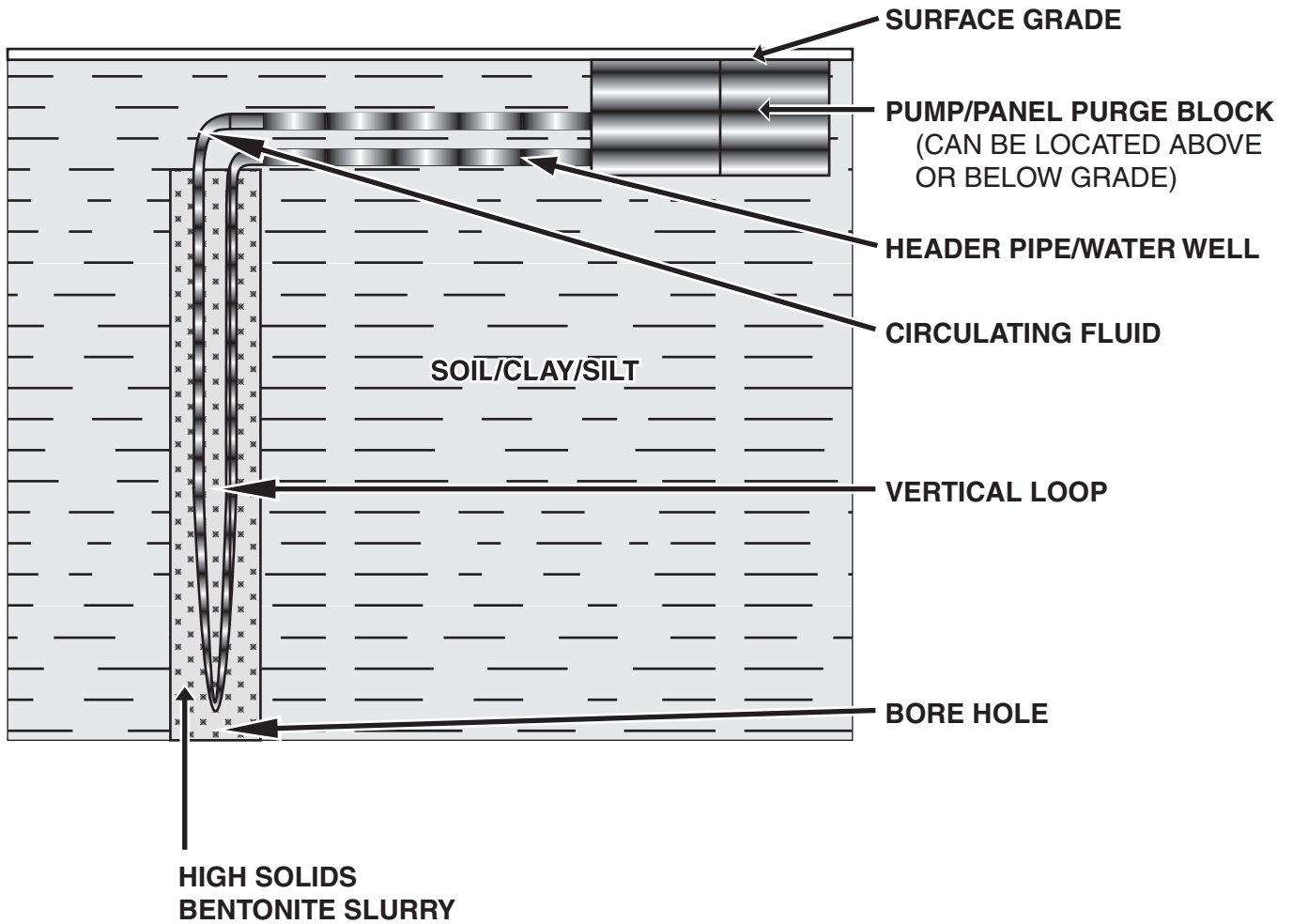

This figure is only for illustrative purposes of the referenced regulation. See the regulation text for the complete standard requirements.

**FIGURE 11B.
 CLOSED LOOP WATER WELL AS PER 46-1212
 LESS THAN 10 BOREHOLES AND LOCATED LESS
 THAN 1000 FEET OF A COMMUNITY PUBLIC WATER WELL**

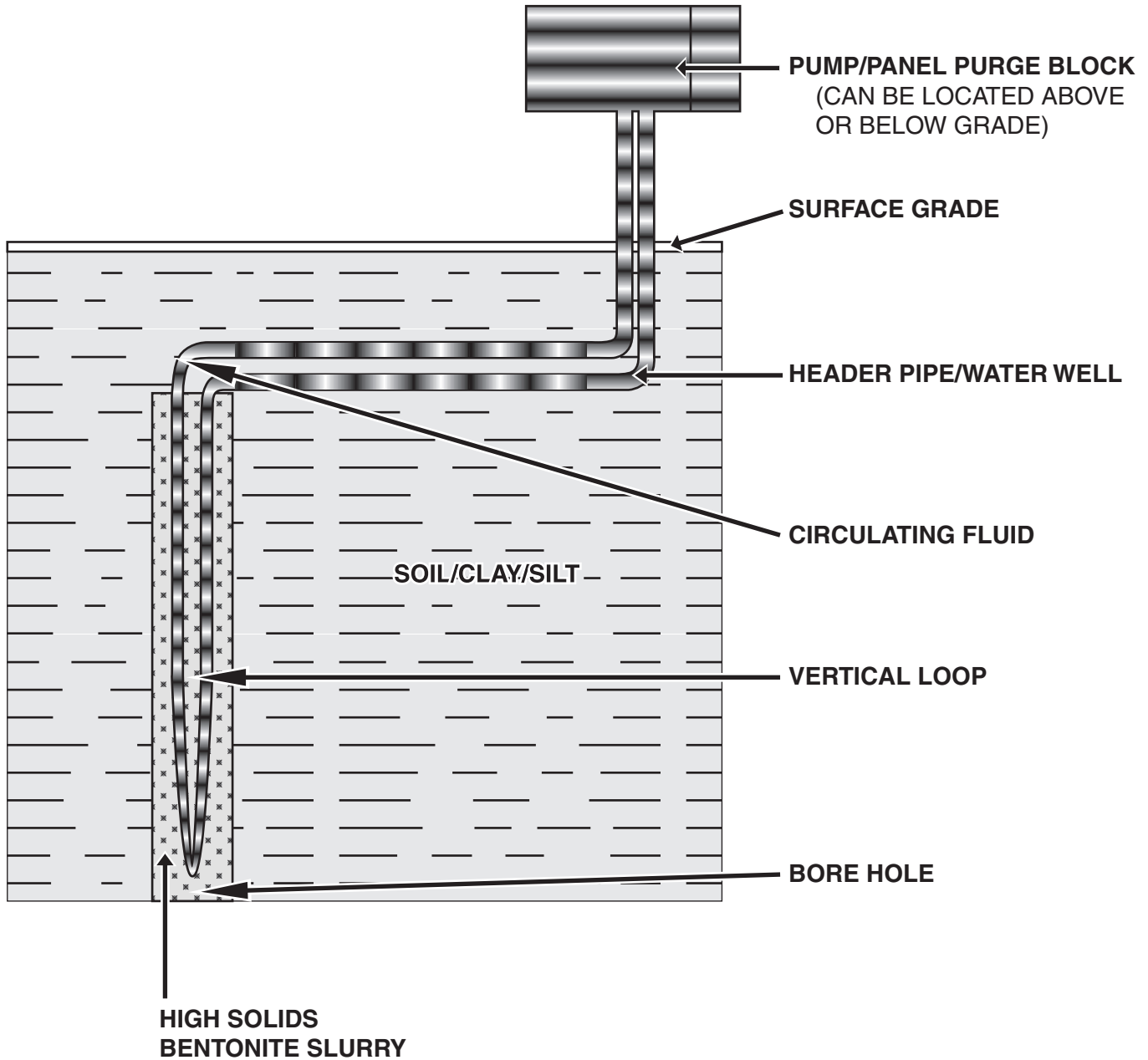

This figure is only for illustrative purposes of the referenced regulation. See the regulation text for the complete standard requirements.

**FIGURE 11C.
CLOSED LOOP WATER WELL AS PER 46-1212
LESS THAN 10 BOREHOLES AND LOCATED
1000 FEET OR MORE OF A COMMUNITY PUBLIC WATER WELL**

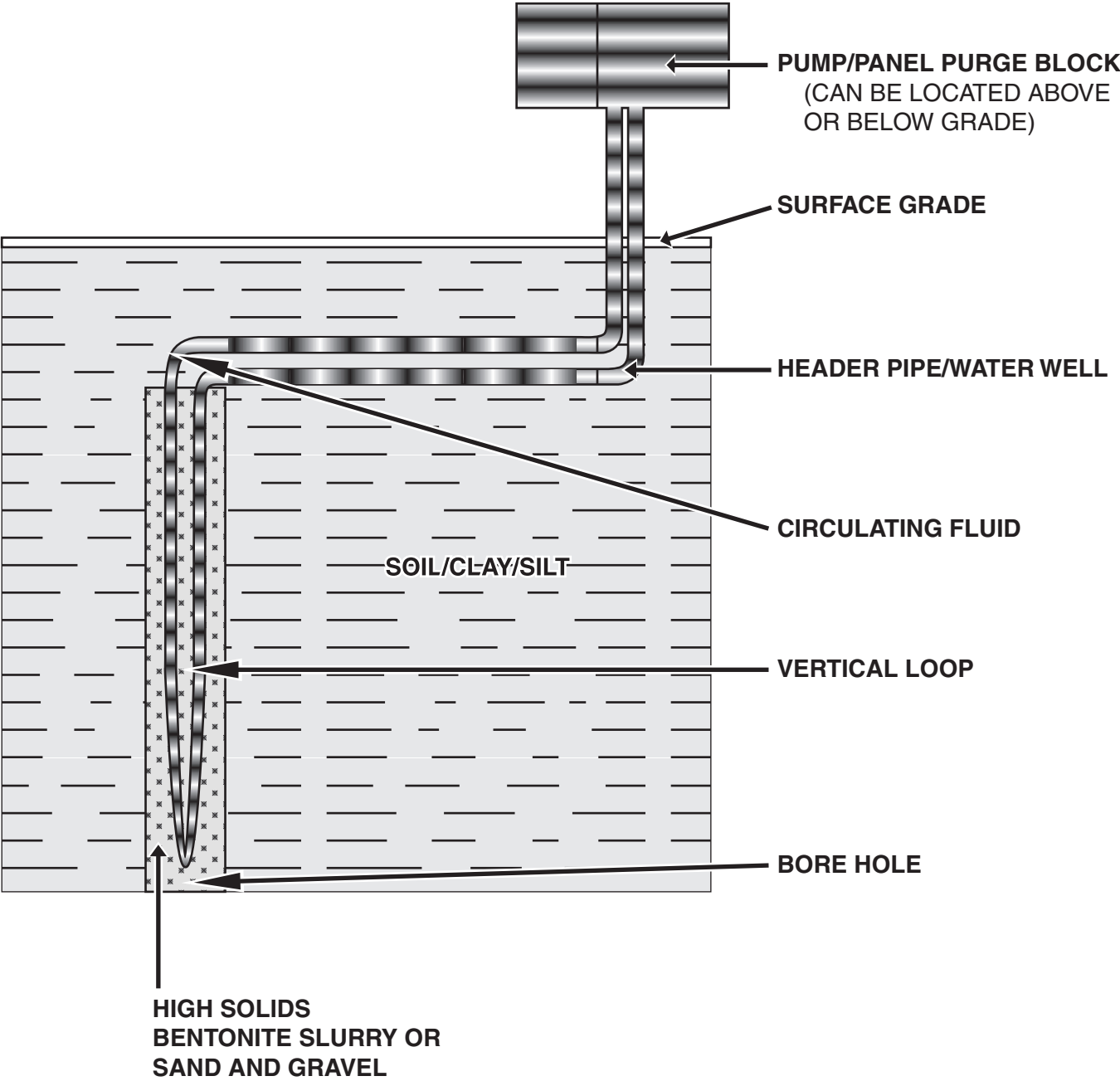

This figure is only for illustrative purposes of the referenced regulation. See the regulation text for the complete standard requirements.

**FIGURE 12.
PITLESS UNITS INSTALLATION
IN A HIGH TRAFFIC AREA**

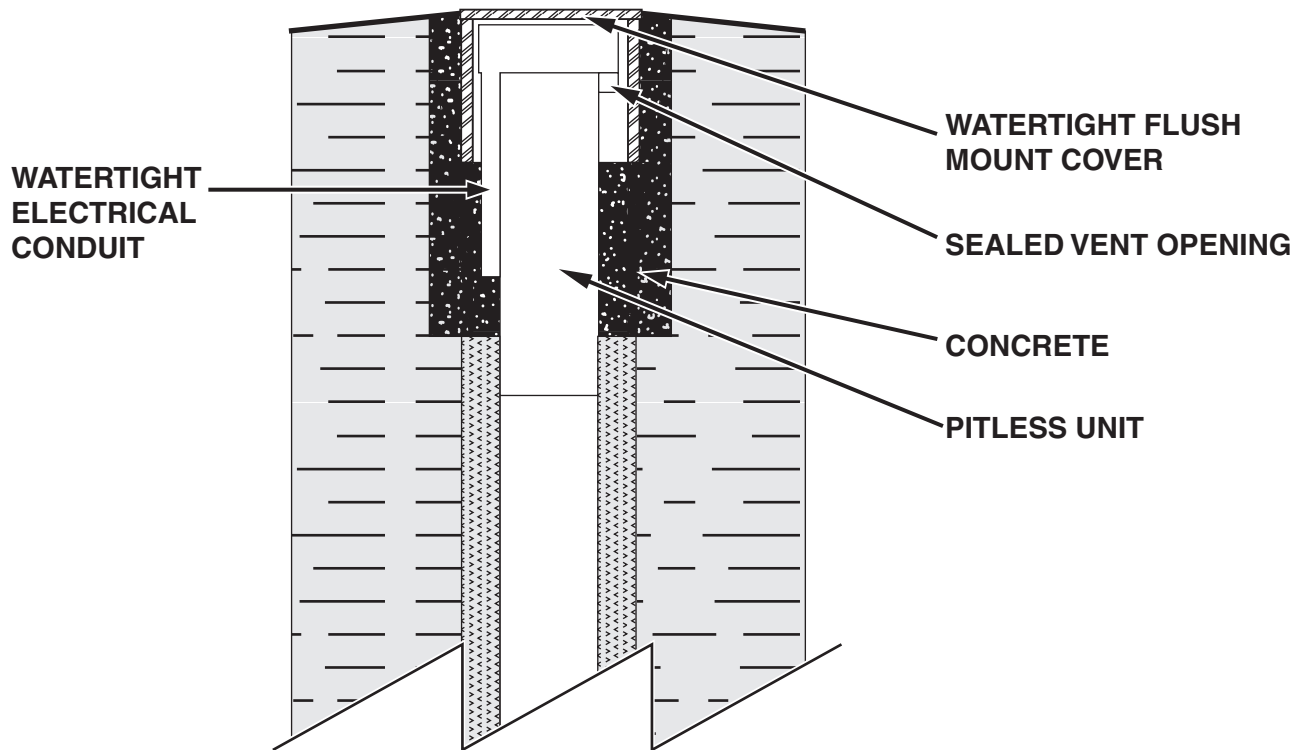

This figure is only for illustrative purposes of the referenced regulation. See the regulation text for the complete standard requirements.

**FIGURE 13.
DECOMMISSIONING THE UPPER PLUG - OPTION 1**

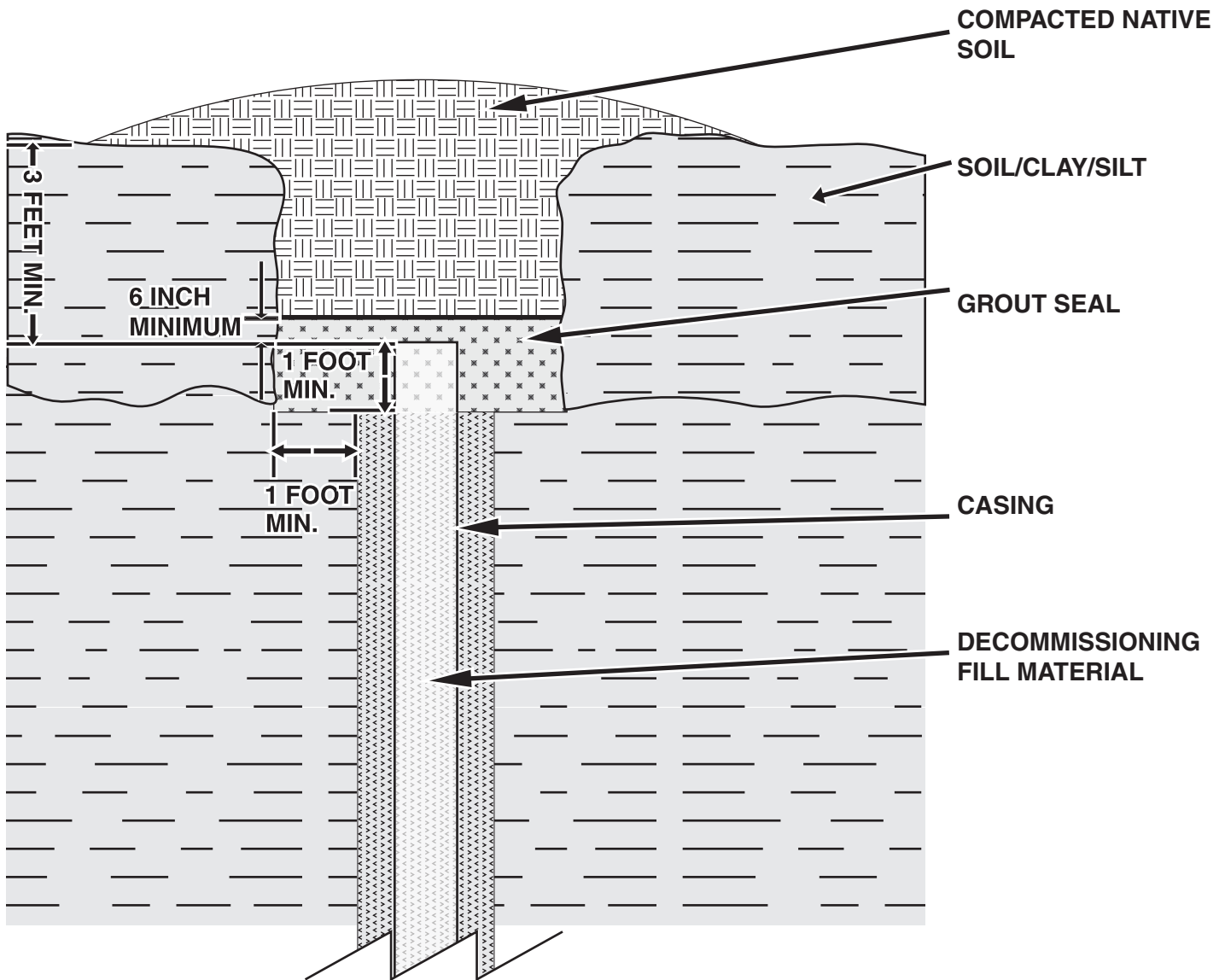

This figure is only for illustrative purposes of the referenced regulation. See the regulation text for the complete standard requirements.

**FIGURE 14.
DECOMMISSIONING THE UPPER PLUG - OPTION 2**

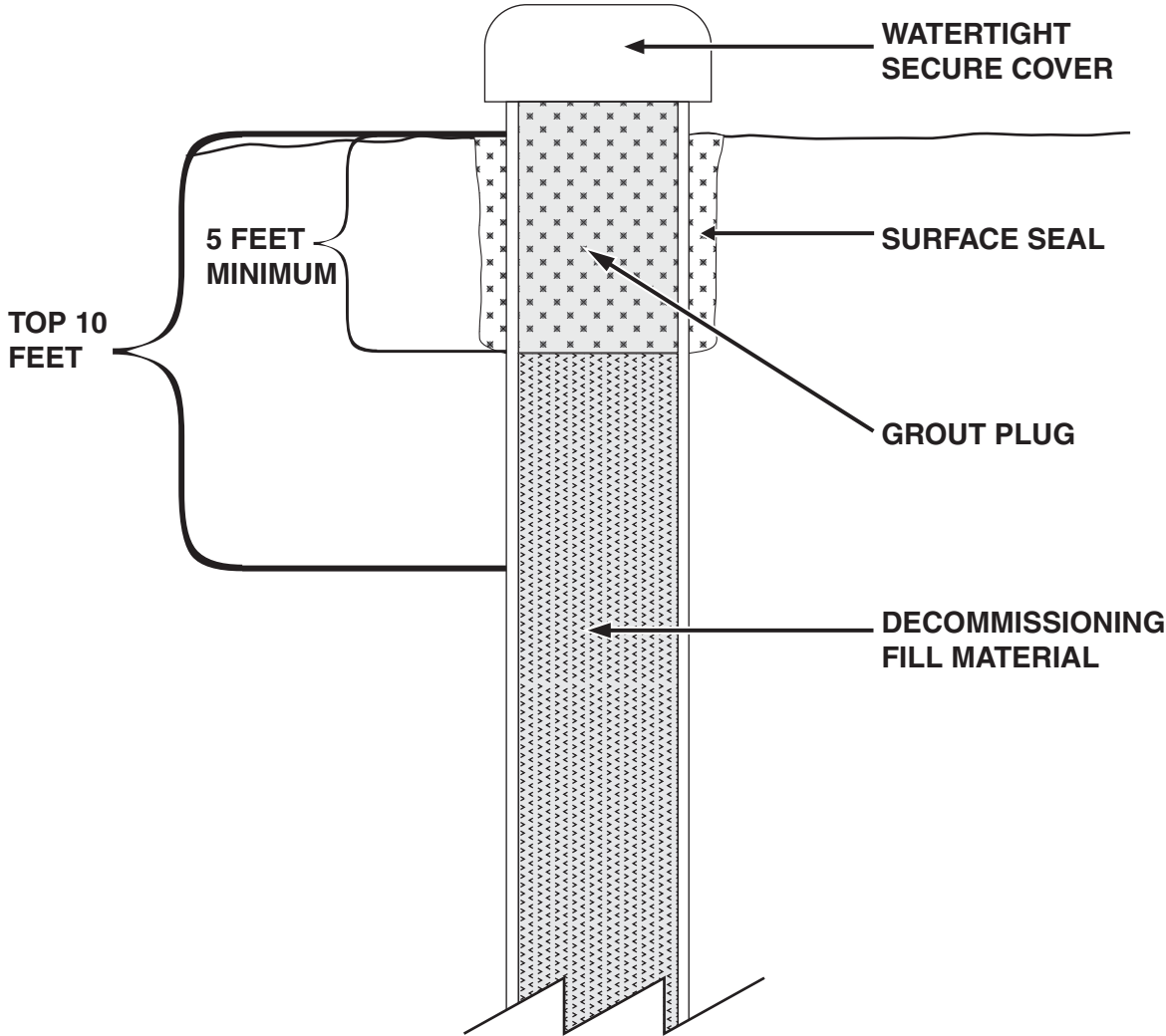

This figure is only for illustrative purposes of the referenced regulation. See the regulation text for the complete standard requirements.

**FIGURE 15.
DECOMMISSIONING THE UPPER PLUG - OPTION 3**

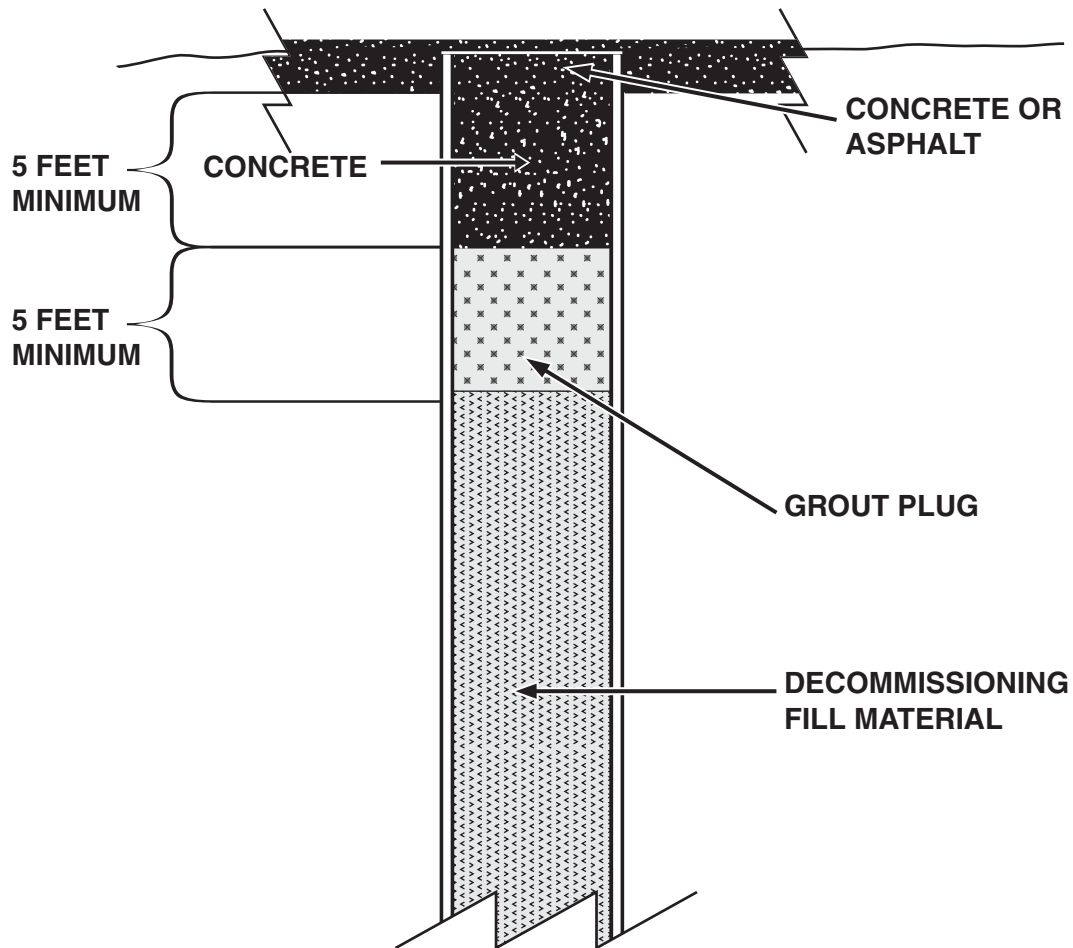

This figure is only for illustrative purposes of the referenced regulation. See the regulation text for the complete standard requirements.

**FIGURE 16.
DECOMMISSIONING DRILLED WELLS**

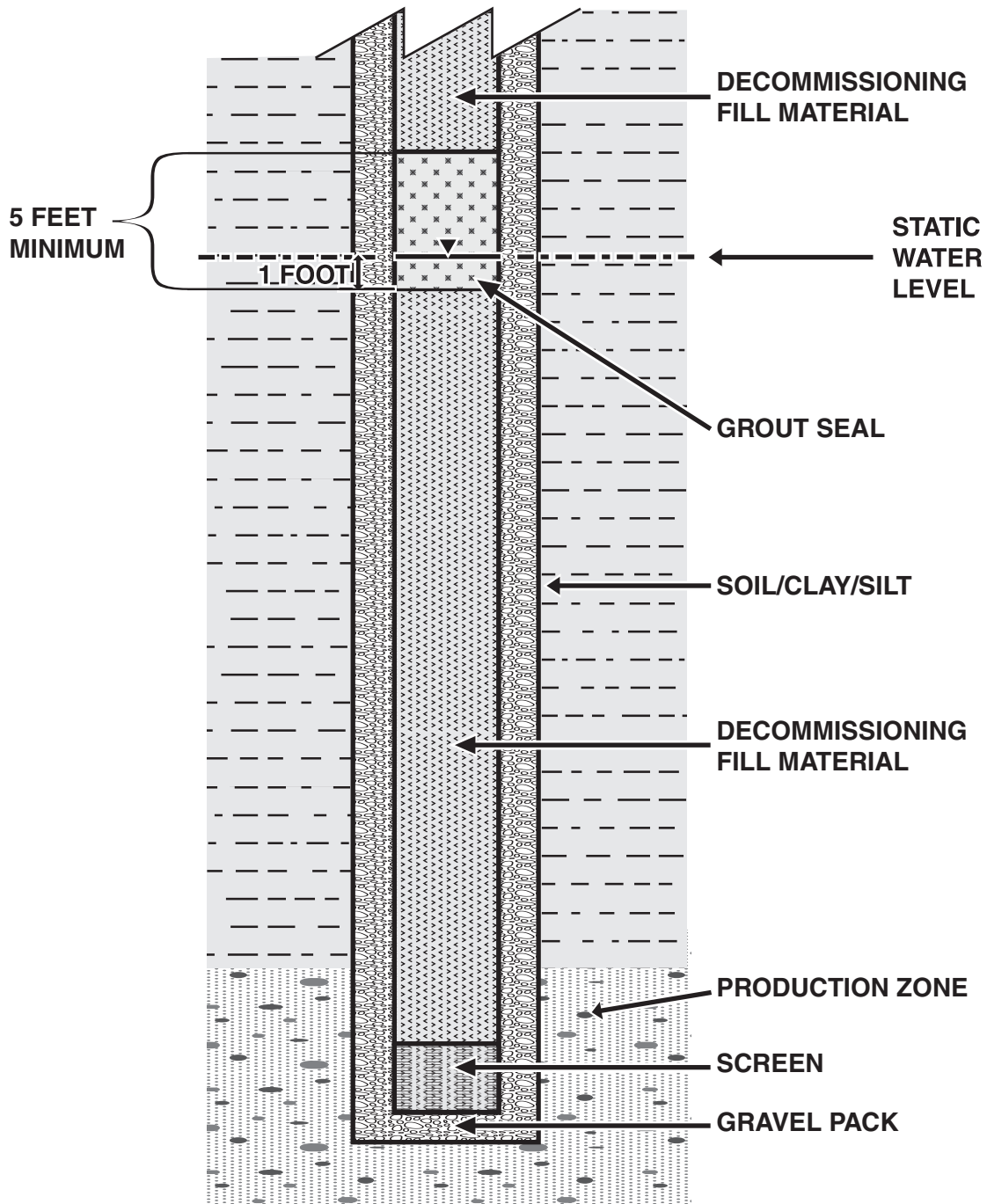

This figure is only for illustrative purposes of the referenced regulation. See the regulation text for the complete standard requirements.

**FIGURE 17.
DECOMMISSIONING DUG OR BORED WATER WELLS**

12-012.08B item 5
12-012.08B item 6

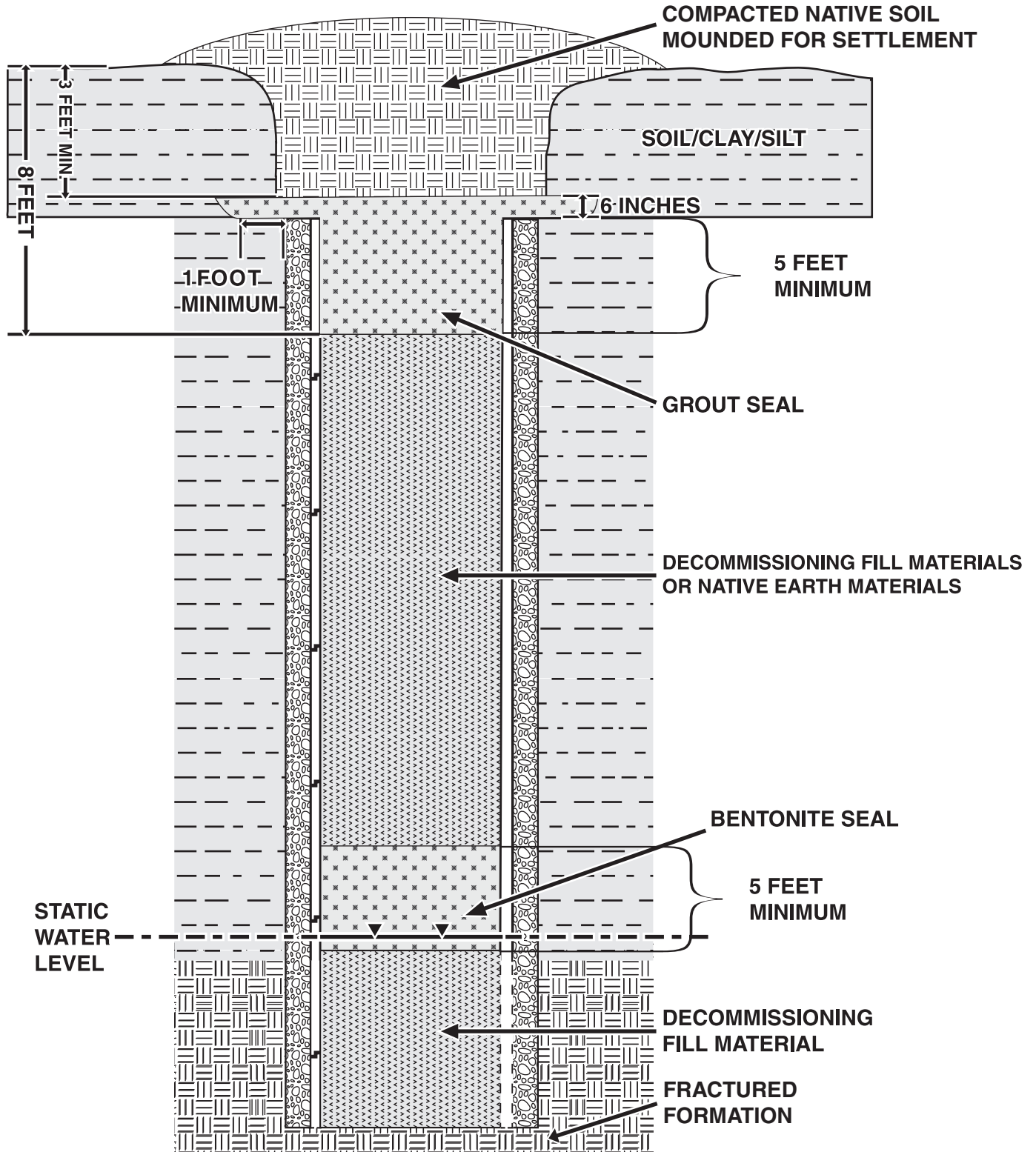

This figure is only for illustrative purposes of the referenced regulation. See the regulation text for the complete standard requirements.

**FIGURE 18.
DECOMMISSIONING DRIVEN SANDPOINT WELLS
WHERE THE CASING IS LEFT IN PLACE**

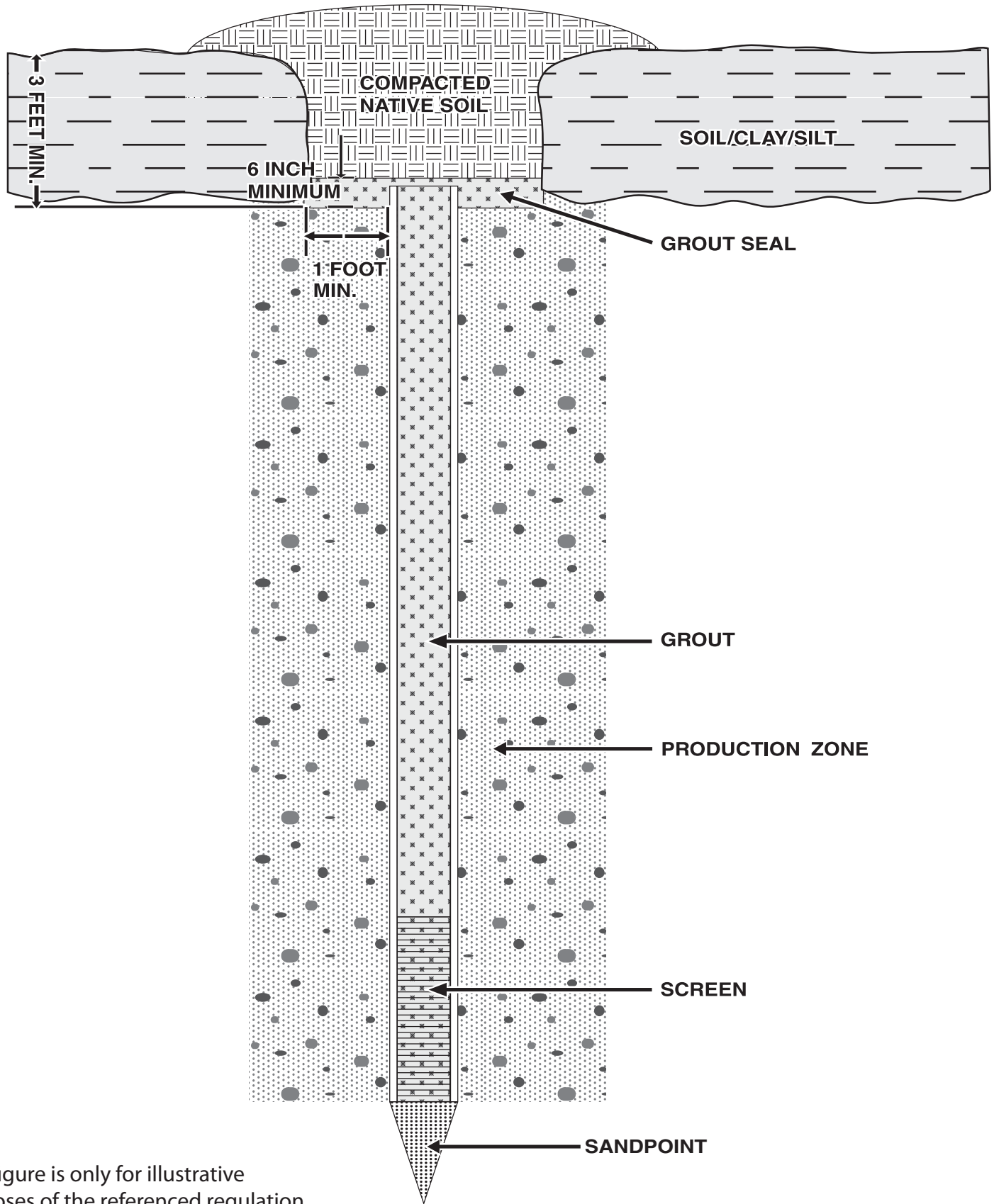

This figure is only for illustrative purposes of the referenced regulation. See the regulation text for the complete standard requirements.

**FIGURE 19.
DECOMMISSIONING FULL LENGTH
GROUTED WELLS**

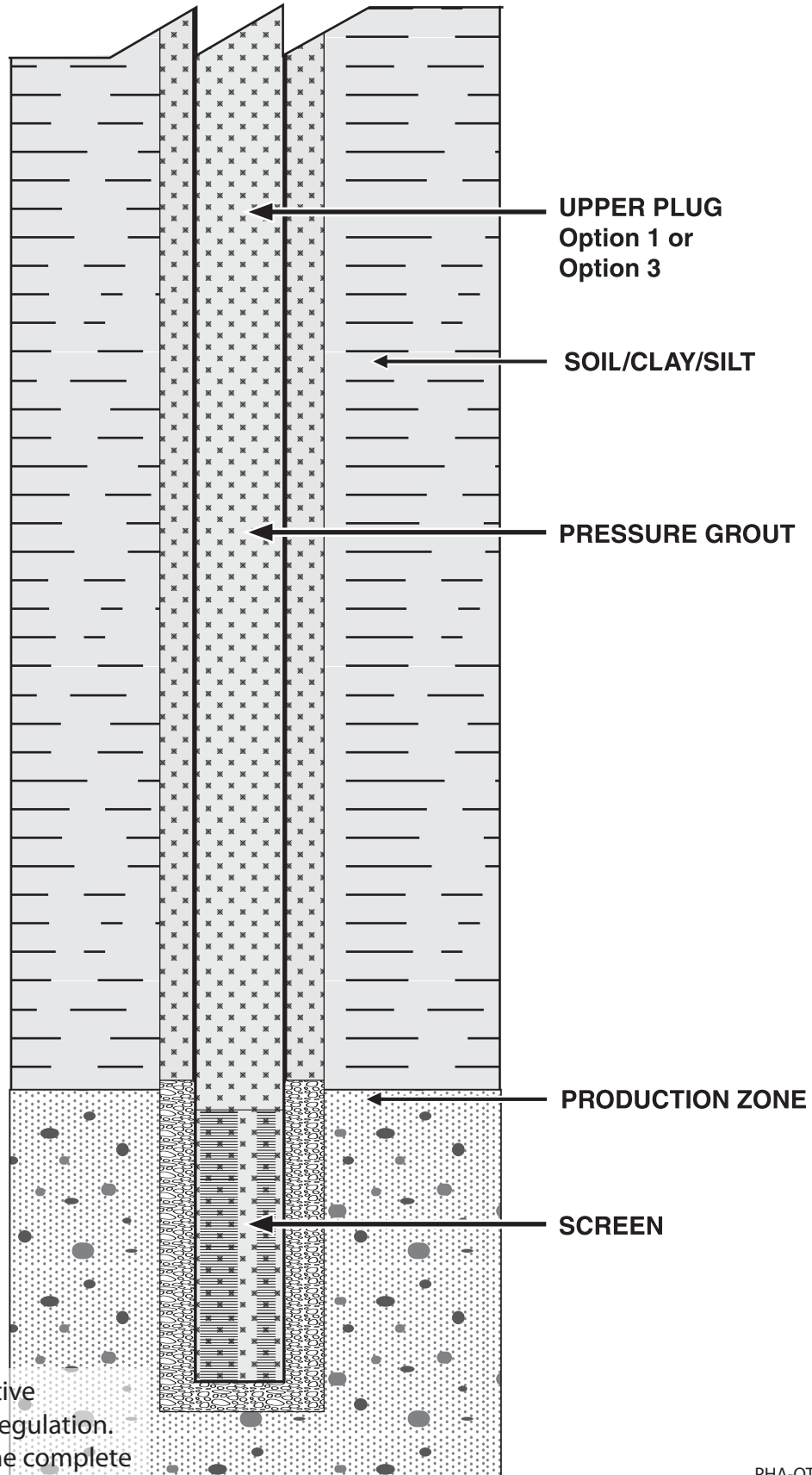

This figure is only for illustrative purposes of the referenced regulation. See the regulation text for the complete standard requirements.

**FIGURE 20.
DECOMMISSIONING MULTIPLE AQUIFER WELLS**

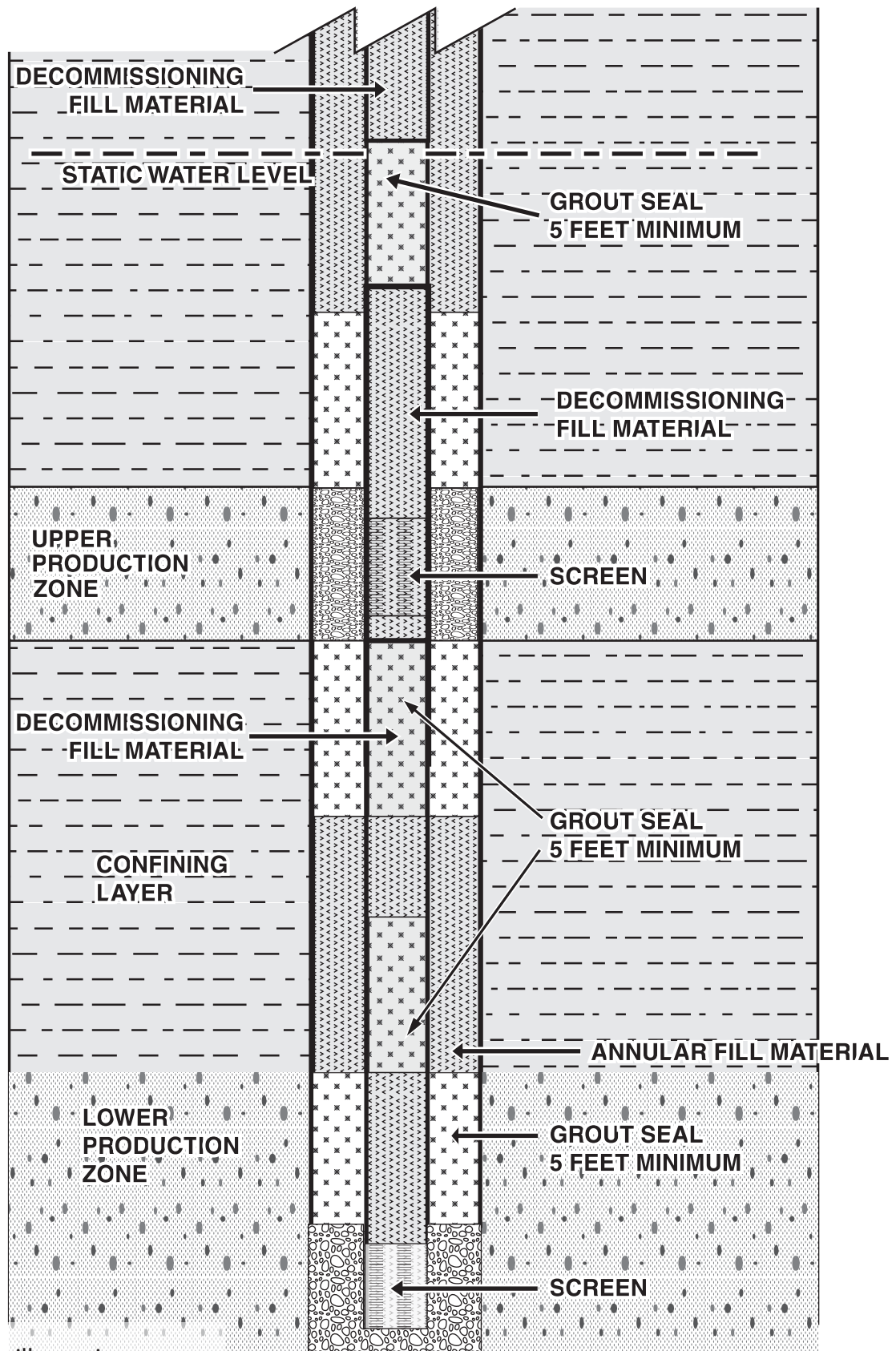

This figure is only for illustrative purposes of the referenced regulation. See the regulation text for the complete standard requirements.

**FIGURE 21.
DECOMMISSIONING FLOWING WATER
WELLS AND CONFINING LAYERS**

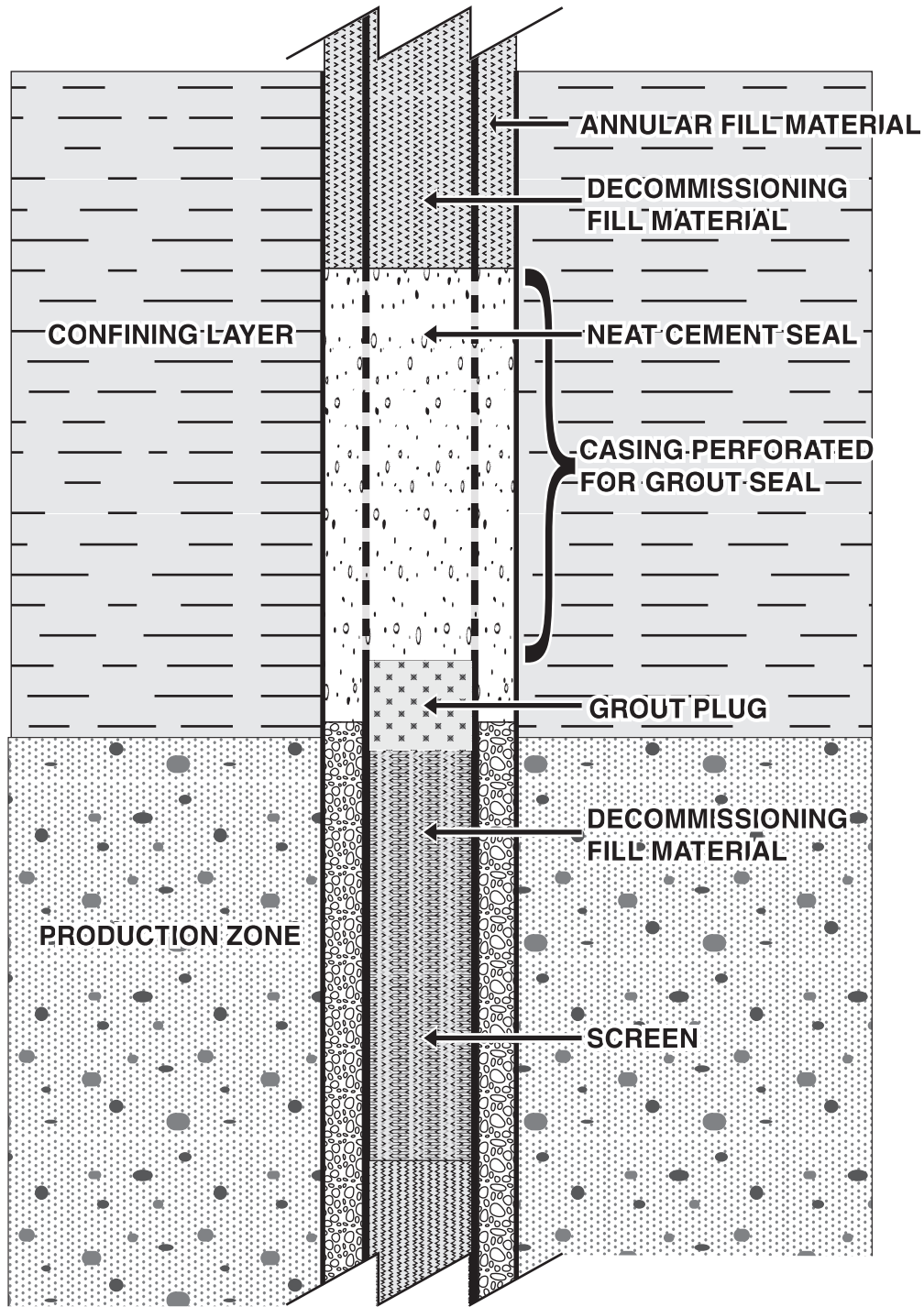

This figure is only for illustrative purposes of the referenced regulation. See the regulation text for the complete standard requirements.