



FTIR Discussion for Ethanol Manufacturers

California Analytical Instruments
www.gasanalyzers.com



Kevin Ramazan, Ph.D.
Vice President of FTIR Operation

kramazan@gasanalyzers.com



BUILDING 1



BUILDING 2

Experience:

Over 30 years in Business

Over 20,000 Analyzers

Markets:

Industry and Automotive

Personnel:

~50 employees

Headquarters:

2 Adjacent Buildings

(Approx. 27,000 square feet)



600 Series

- NDIR – CO, CO₂, CH₄, SO₂
- FID/HFID – Total Hydrocarbons
- CLD/HCLD – NO, NO₂, NO_x
- Oxygen Analyzers

Other

- FTIR
- Photo acoustic Multi-gas Analyzers
- Zero Air Generators – ZAG
- Multipoint Samplers
- Custom Sample Conditioning
- Land Fill Gas Systems
- Automotive Test Systems
- Boiler Monitoring Systems
- Other Custom Systems

- FTIR – Stands for Fourier Transform Infrared Radiation Spectroscopy
- The Fourier transform is a mathematical function that converts from the time domain to the frequency domain:

$$\hat{f}(\xi) = \int_{-\infty}^{\infty} f(x) e^{-2\pi i x \xi} dx$$

- Infrared is radiation from a specific region of the light spectrum where most gas molecules absorb
- FTIR is a type of spectroscopy, which is the study of the interaction between matter (gases) and radiated energy (or light)
- CAI's FTIR gas analyzer is utilized to analyze hot/wet gas samples for many components.

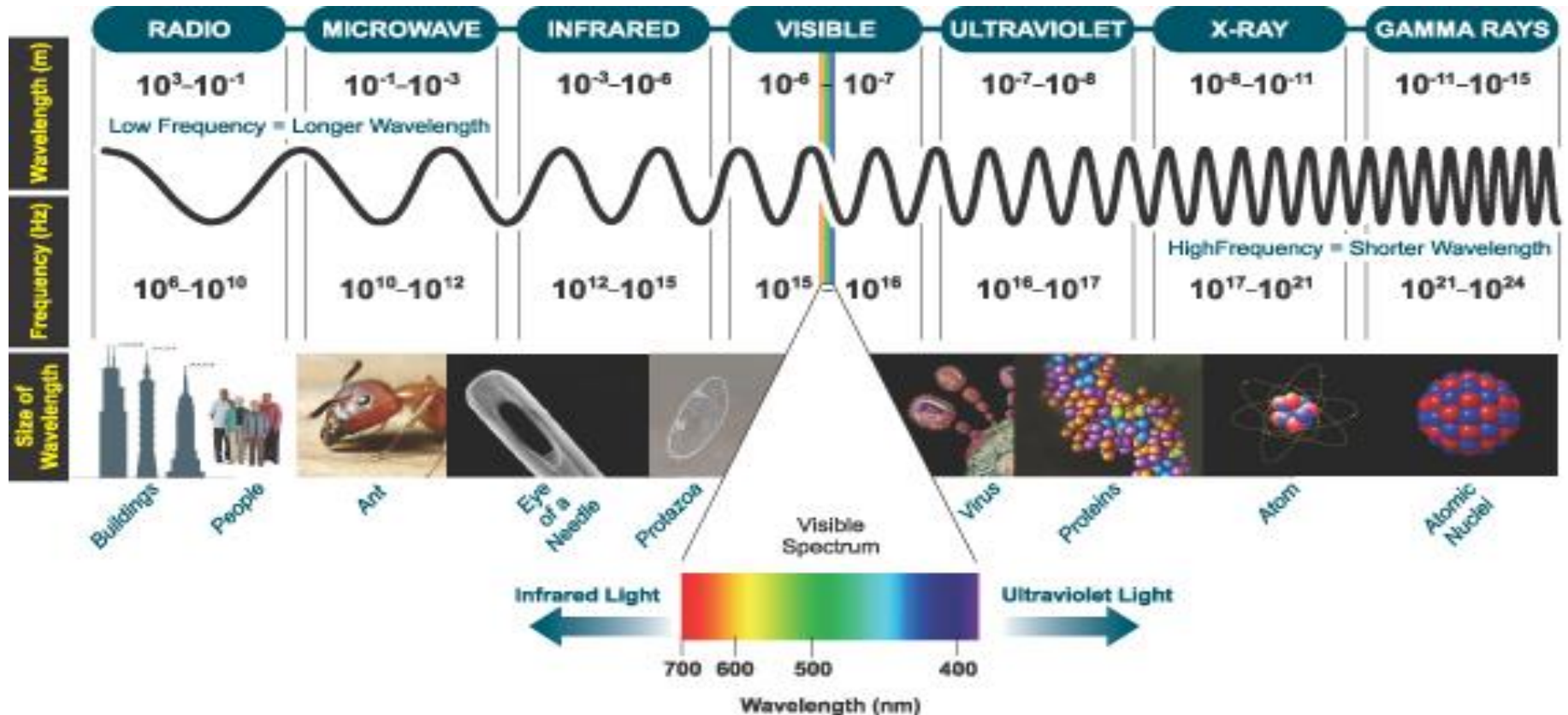

- Infrared is invisible light ranging from 1mm to 750nm in wavelength
- Infrared light can be divided into three parts:
 - Far infrared - 1mm to 10 μ m
 - Mid infrared - 10 μ m to 2.5 μ m ← most components have strongest absorption here
 - Near infrared - 2.5 μ m to 750 nm



- Not every molecule absorbs infrared light
 - Monoatomic
 - He, Ar, Ne, etc...
 - Homoatomic diatomic
 - N₂, O₂, H₂, etc...
- Several molecules do absorb infrared light
 - The CH₂ bond in hydrocarbons are a good example:

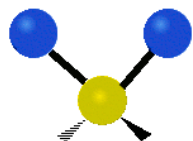

Symmetrical stretching

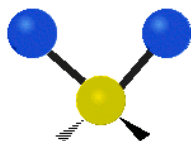

Asymmetrical stretching

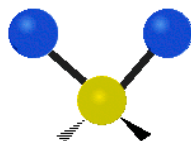

Scissoring or bending

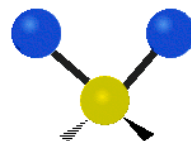

Rocking

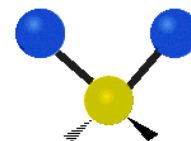

Wagging

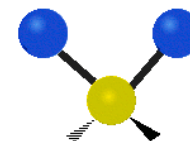

Twisting

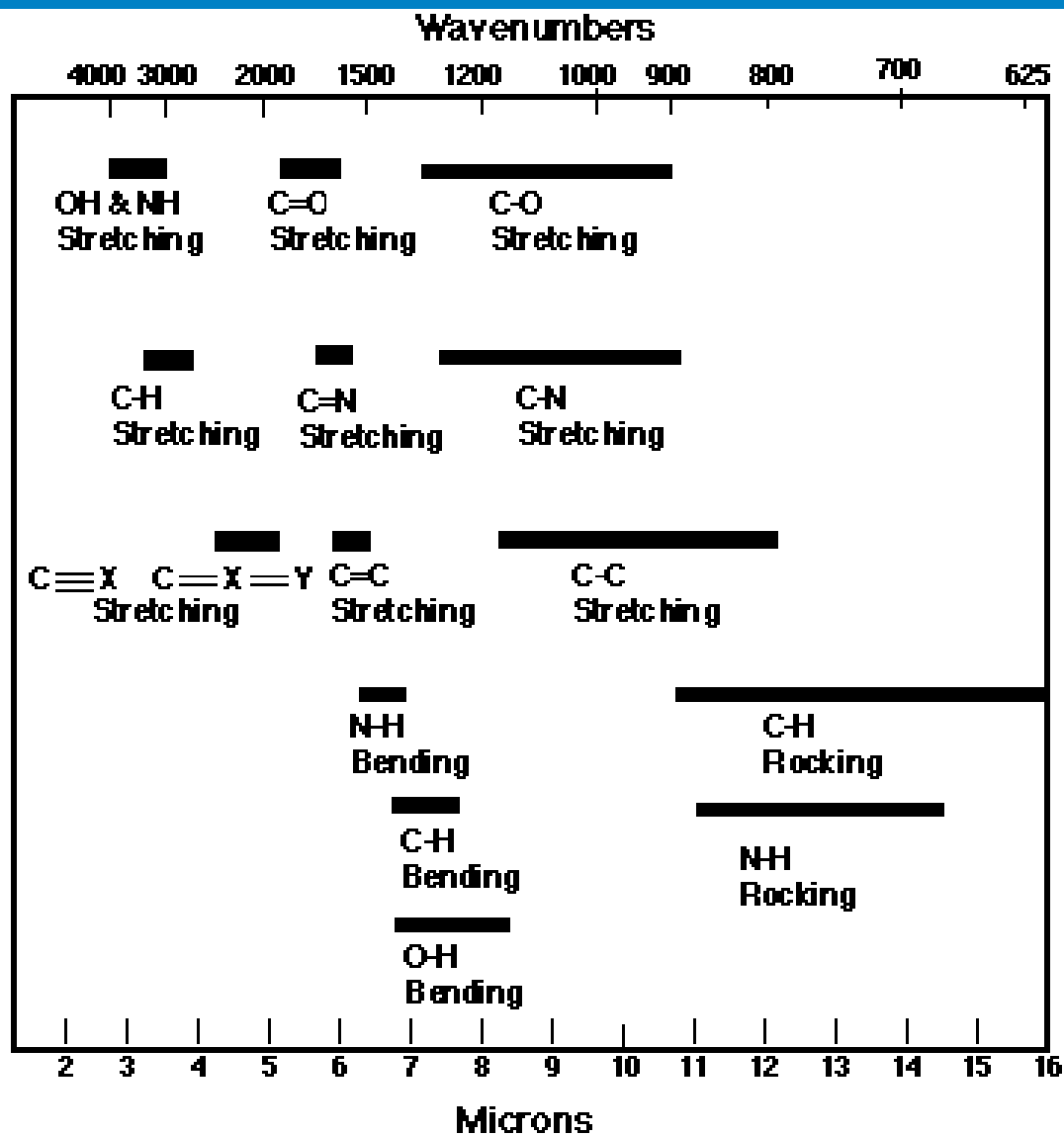

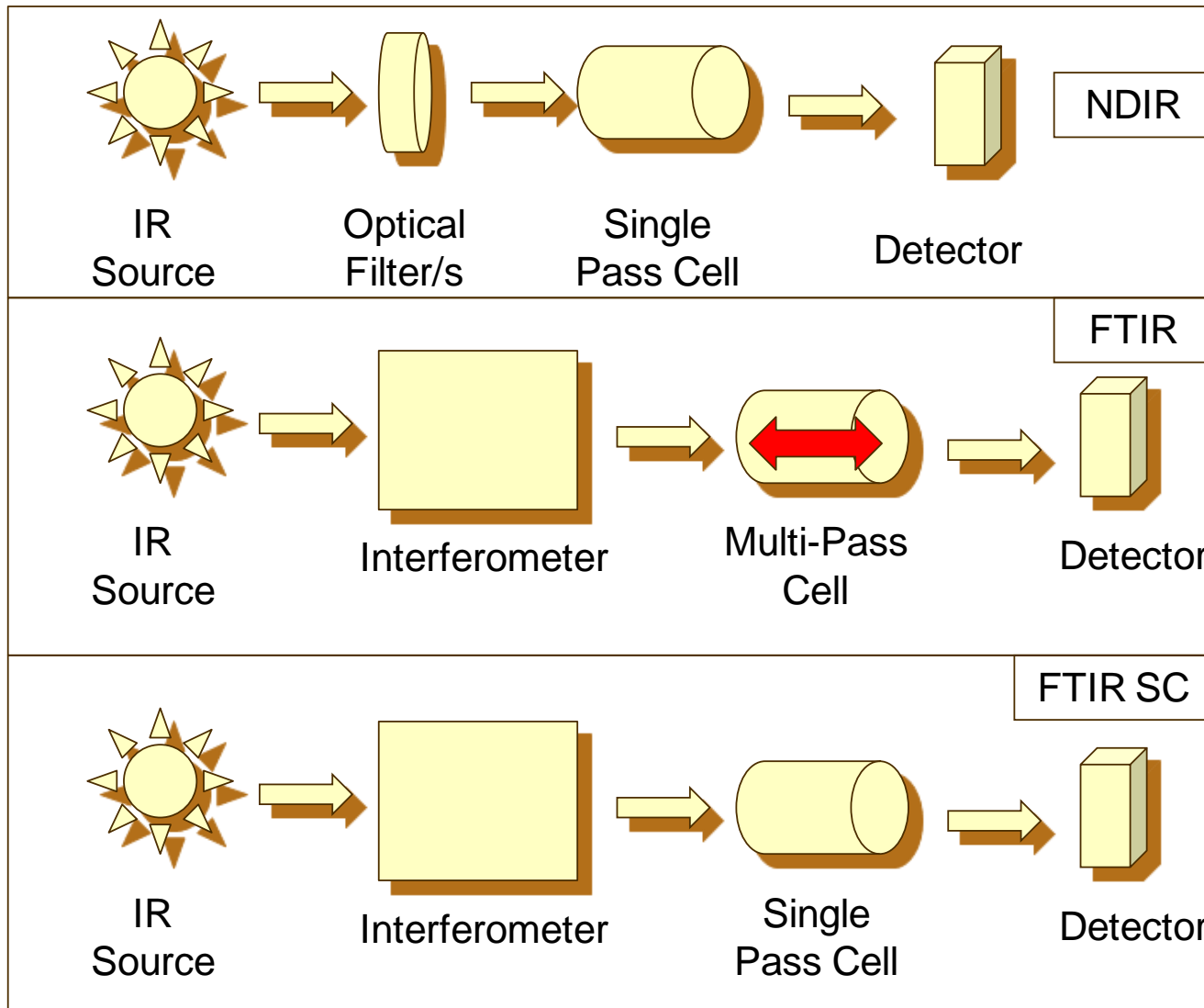

- The Michelson interferometer principle
- Monochromatic light

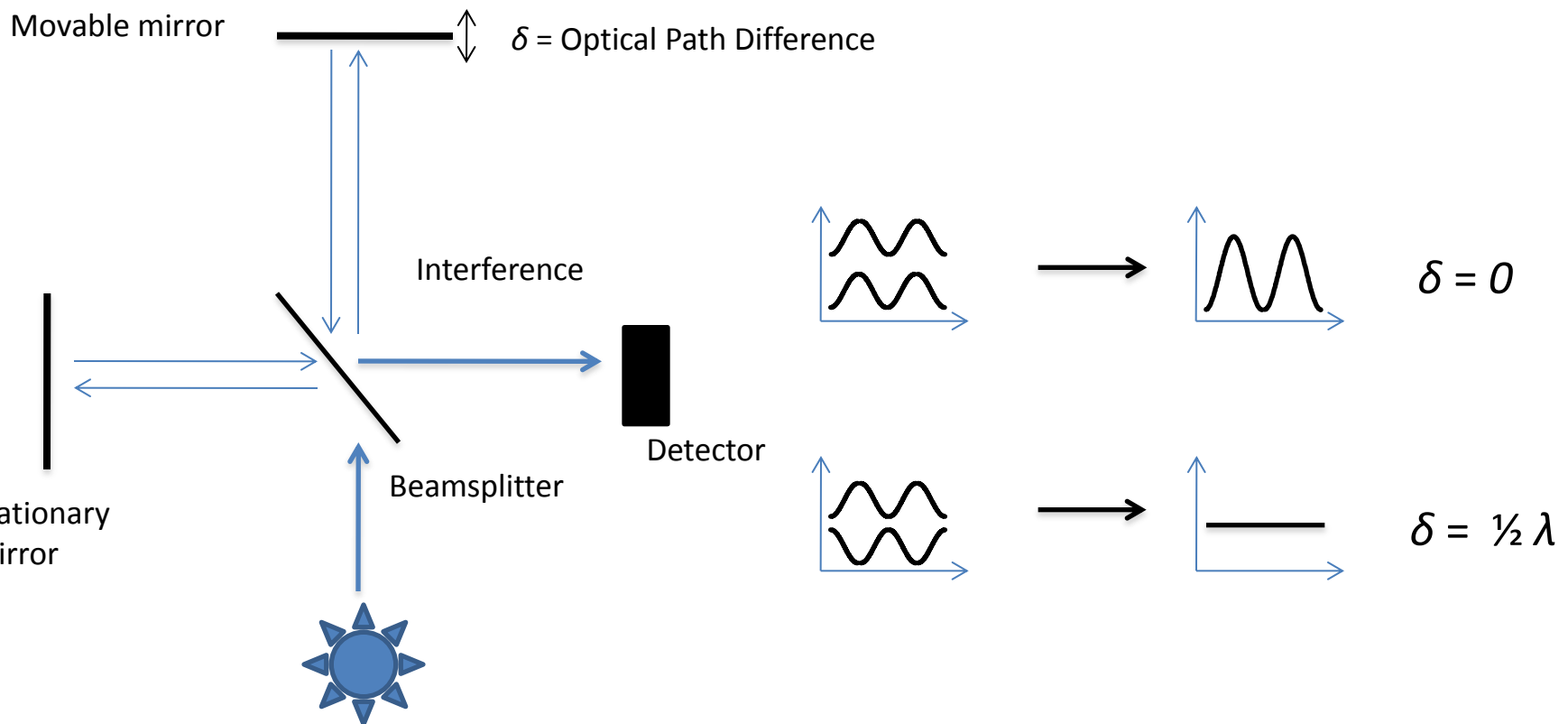

- Dichromatic source

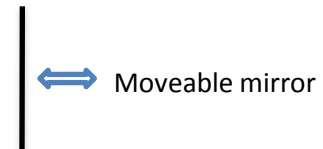
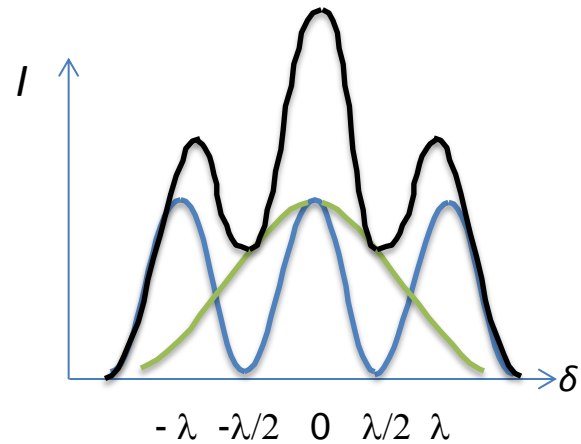
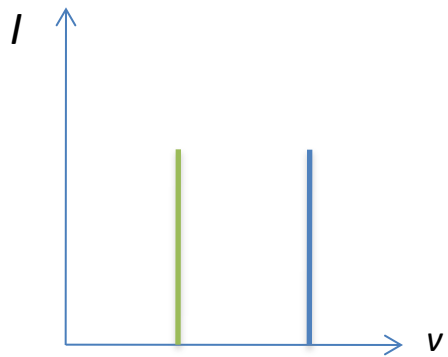

- Broadband source

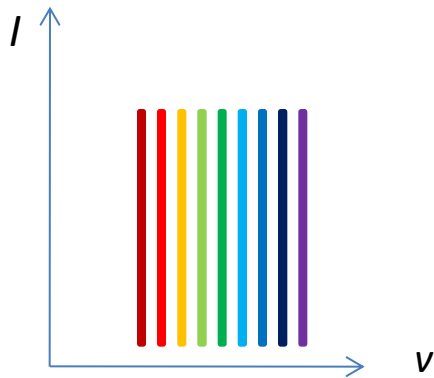

Continuous IR spectrum

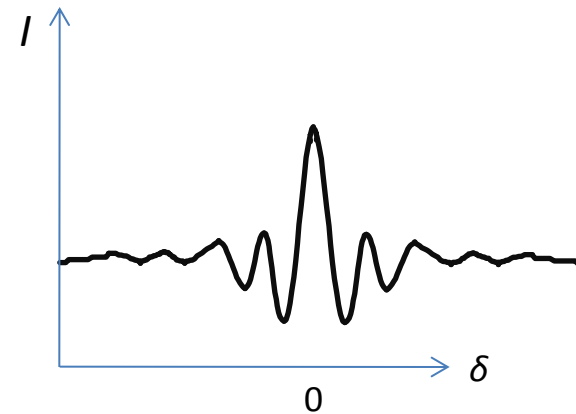

Interferogram

$$I(\delta) = \int_{-\infty}^{\infty} B(\nu) \cos(2\pi\nu\delta) d\nu$$



FT

$$B(\nu) = \int_{-\infty}^{\infty} I(\delta) \cos(2\pi\nu\delta) d\delta$$

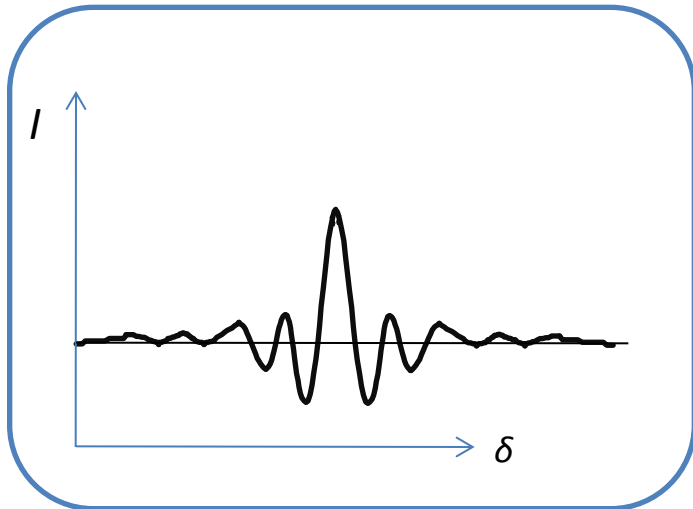

Time domain: I vs. δ

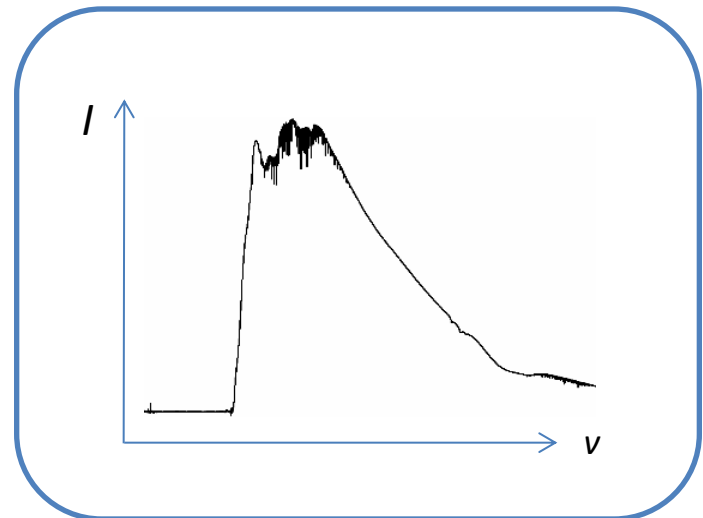

Frequency domain: I vs. ν

- The highest peak intensity is attained when $AB=AC$
- The maximum of the highest intensity peak is called the zero path difference (ZPD) point
- After the interferogram has been created by the instrument, the Fourier transform is applied to it, which then results in a single beam spectrum

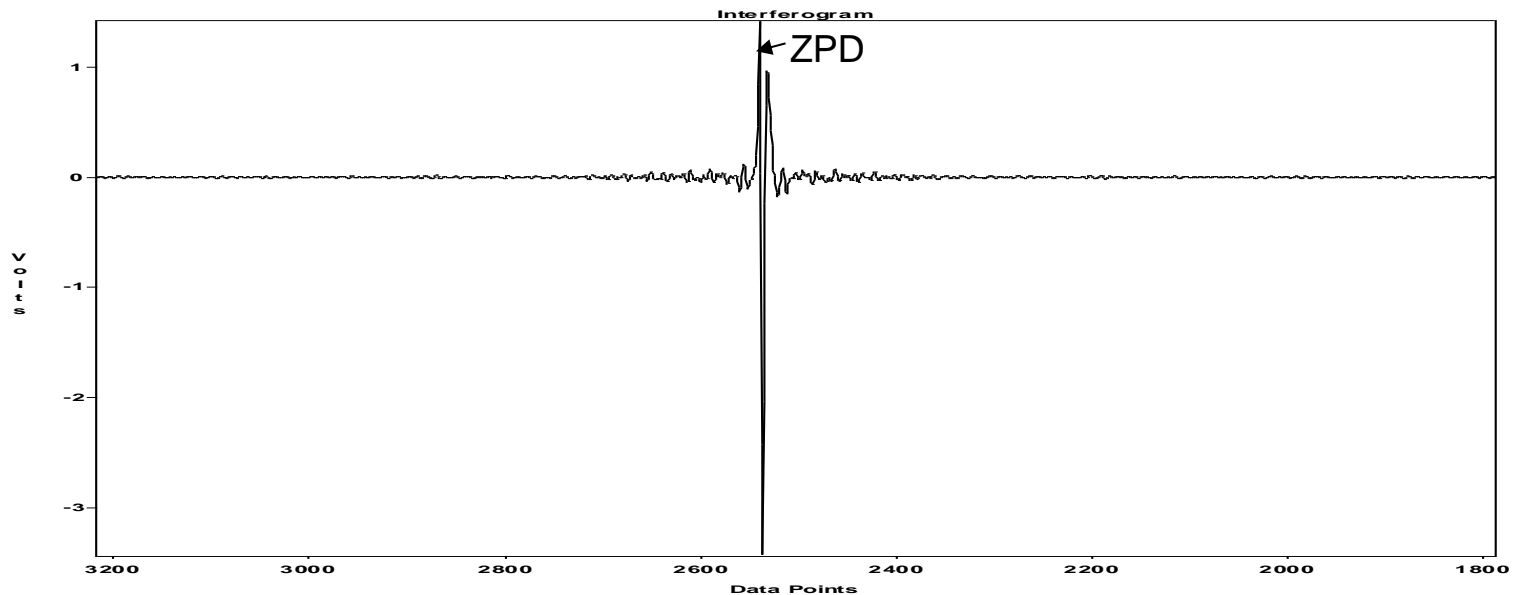



Single Beam Spectrum (Background)

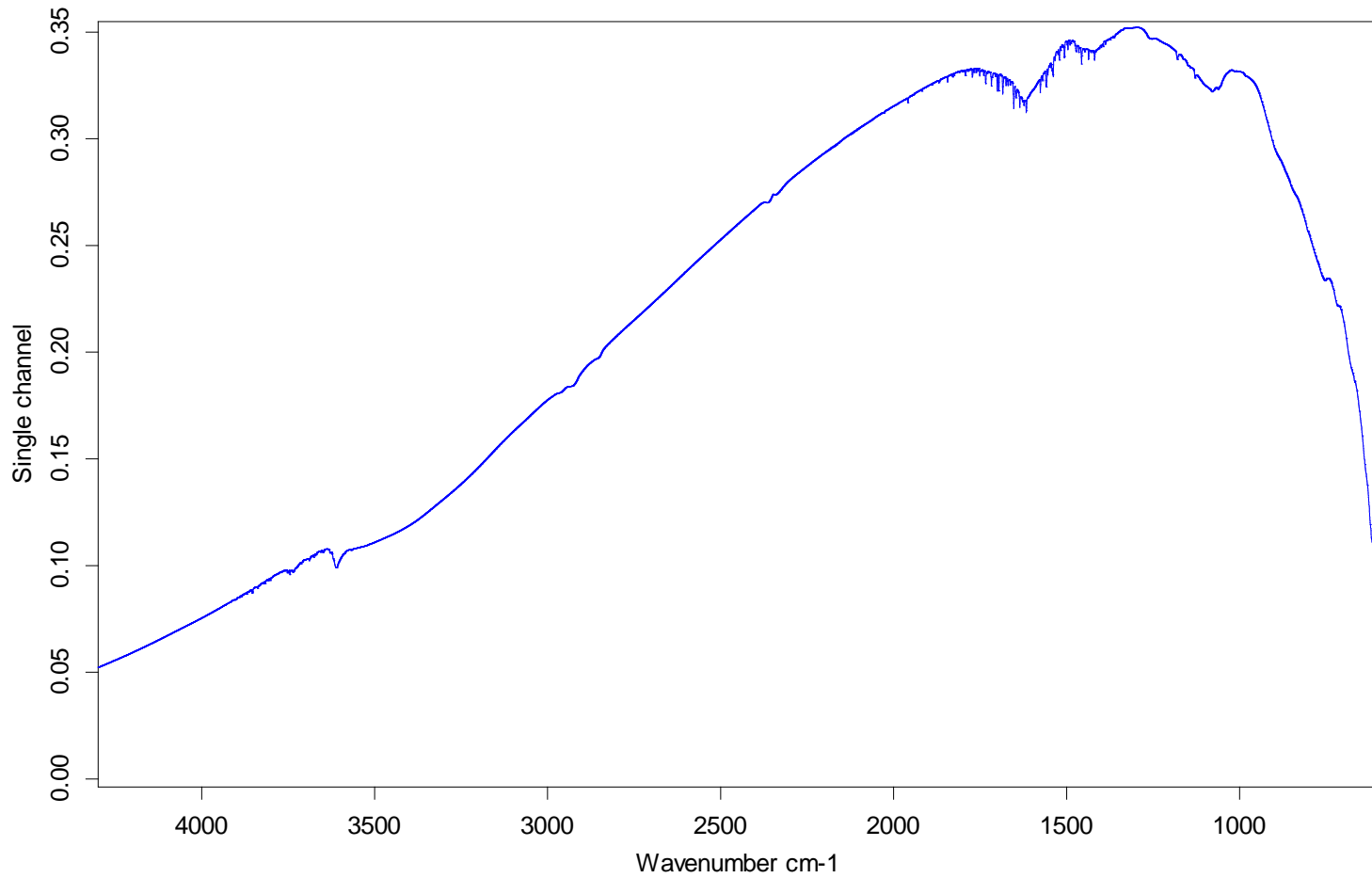



Single Beam Spectrum (Sample)

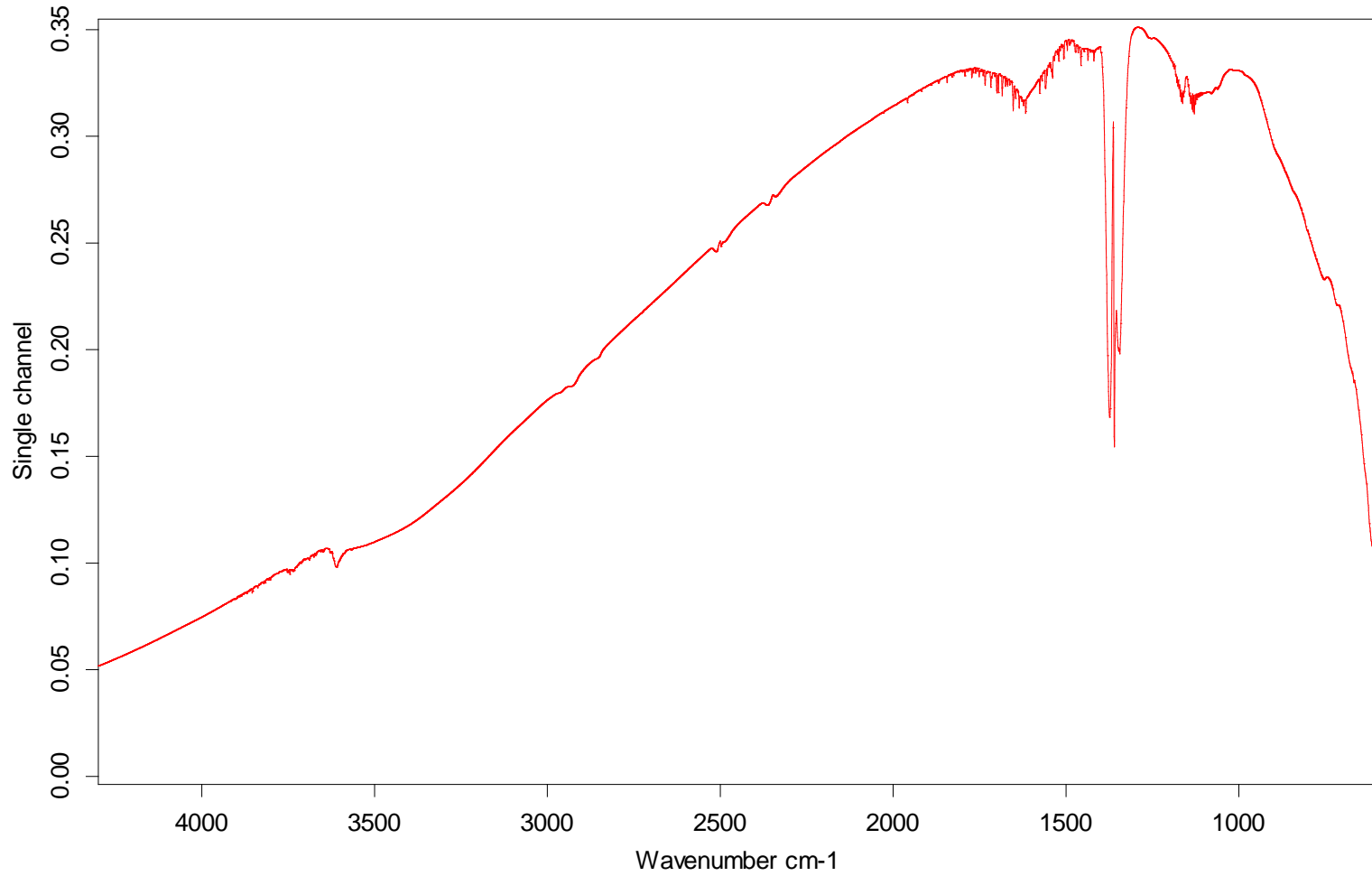



Single Beam Spectrum (Background + Sample)

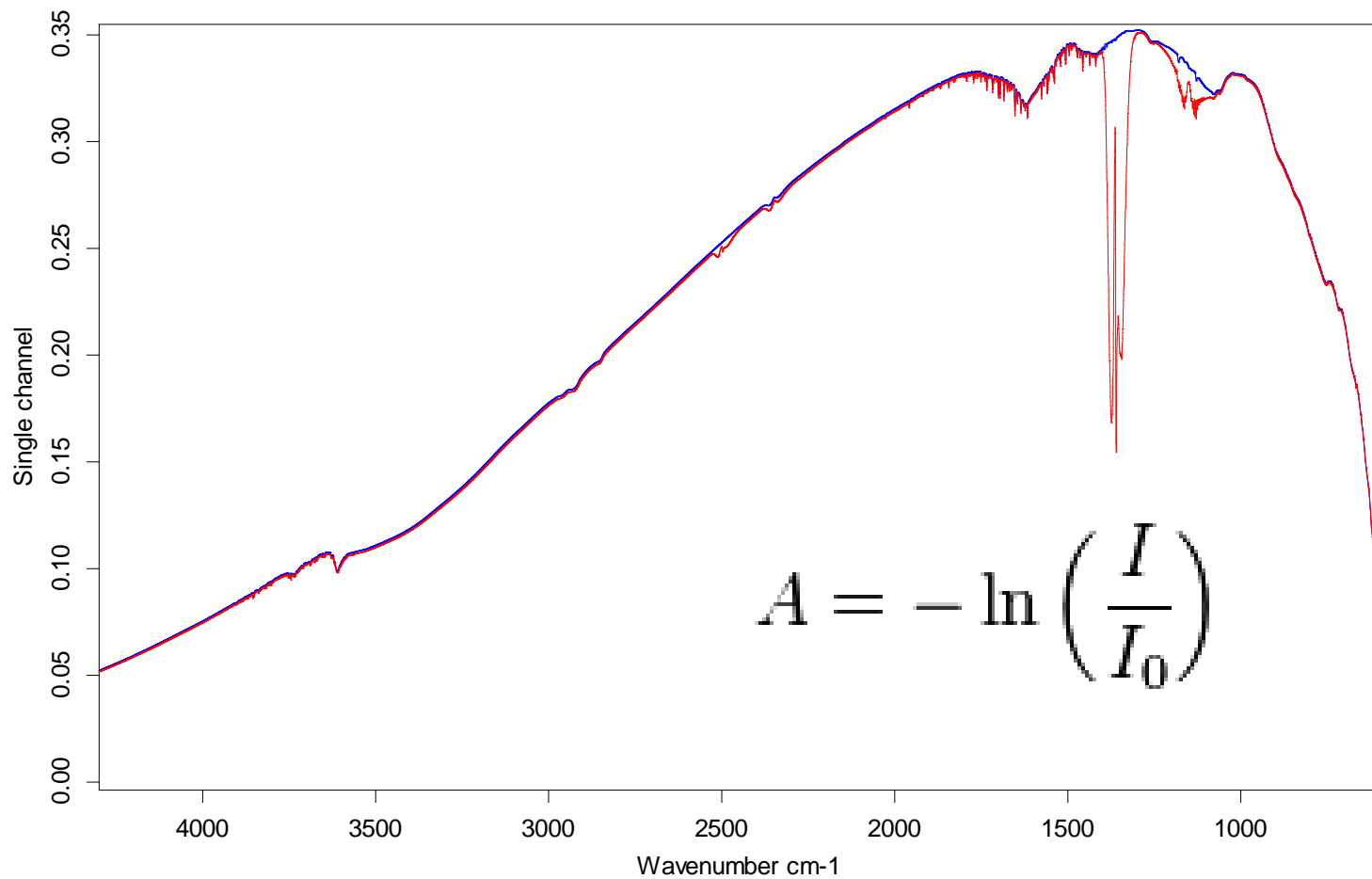



Absorbance

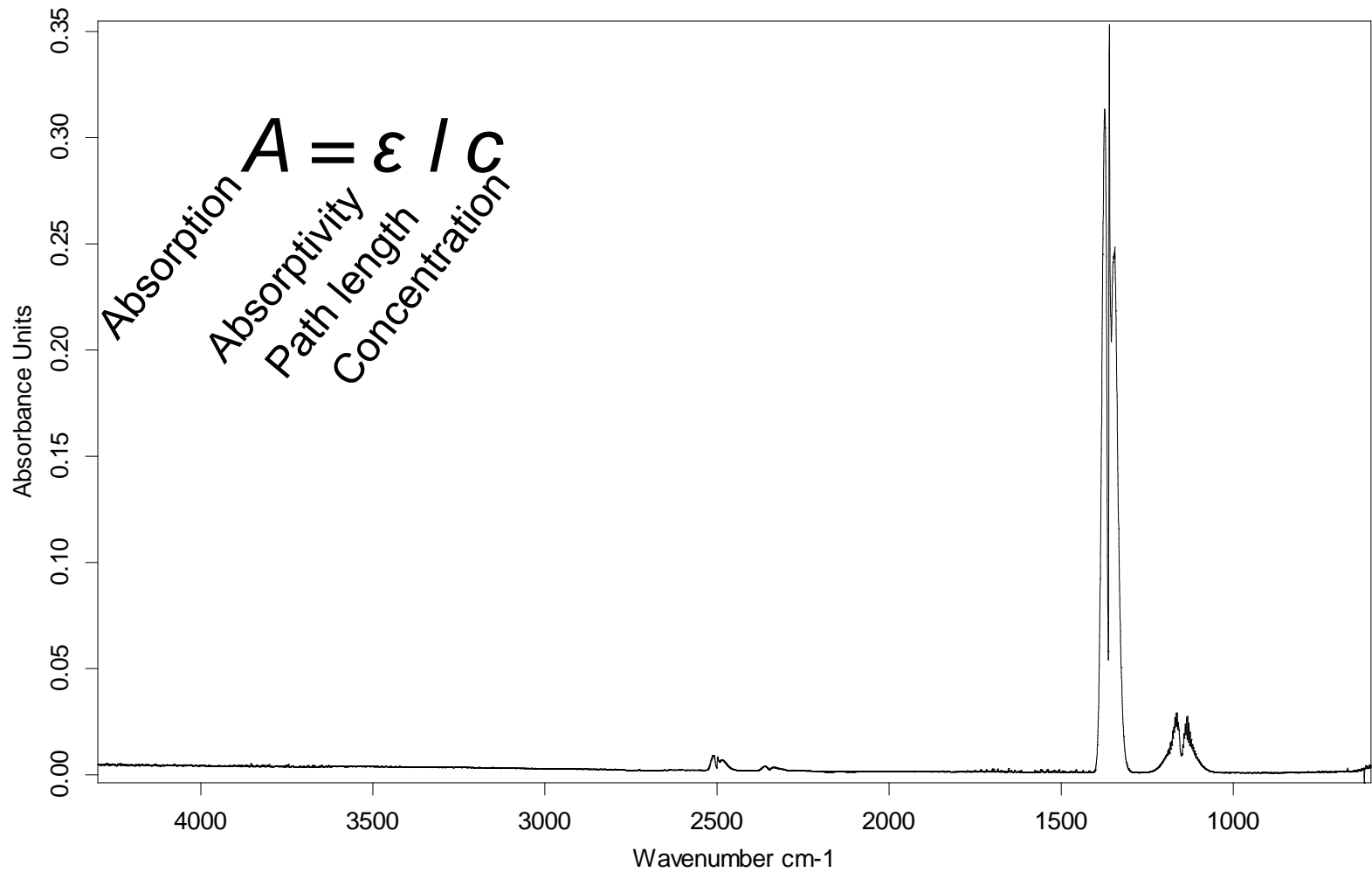

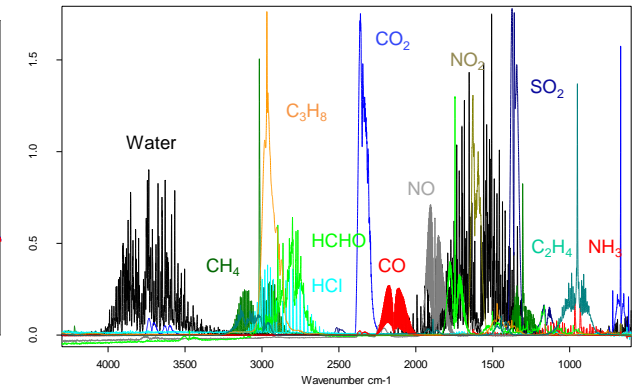
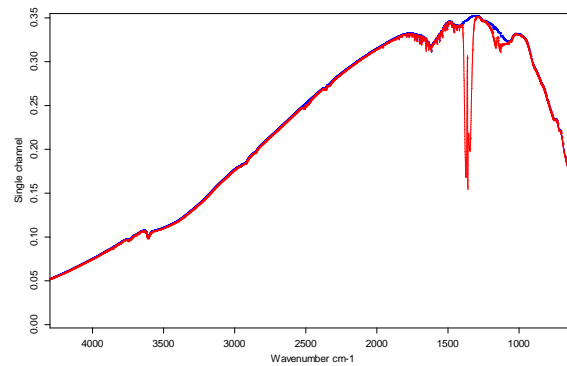
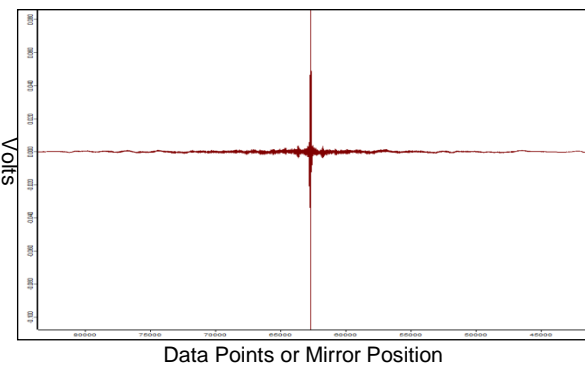

Interferogram

→
Signal Processing & Fourier Transform

Single Beam

→
Normalization ratio sample to reference
 $A = \text{Log}_{10} (I_0 / I)$

Absorbance Spectrum ready for speciation / quantification



CAI FTIR



FEATURES

- Measures multiple components simultaneously
- Can measure most components from sub-ppm to percent levels
- Sample Cell is heated to 50°C or 191°C
- Fast Response
- Small Form Factor
- Ease to use software interface
- NO LIQUID NITROGEN REQUIRED

BENEFITS

- Only need one analyzer - saves money & space
- Flexibility for many applications
- Ambient or hot/wet applications – no need for sample conditioning
- Easily catches spikes in concentrations
- Transportable or rack mountable
- Anyone can operate and communicate
- Eliminates the hassle and cost of liquid N2



700 Series FTIR—Internal Components

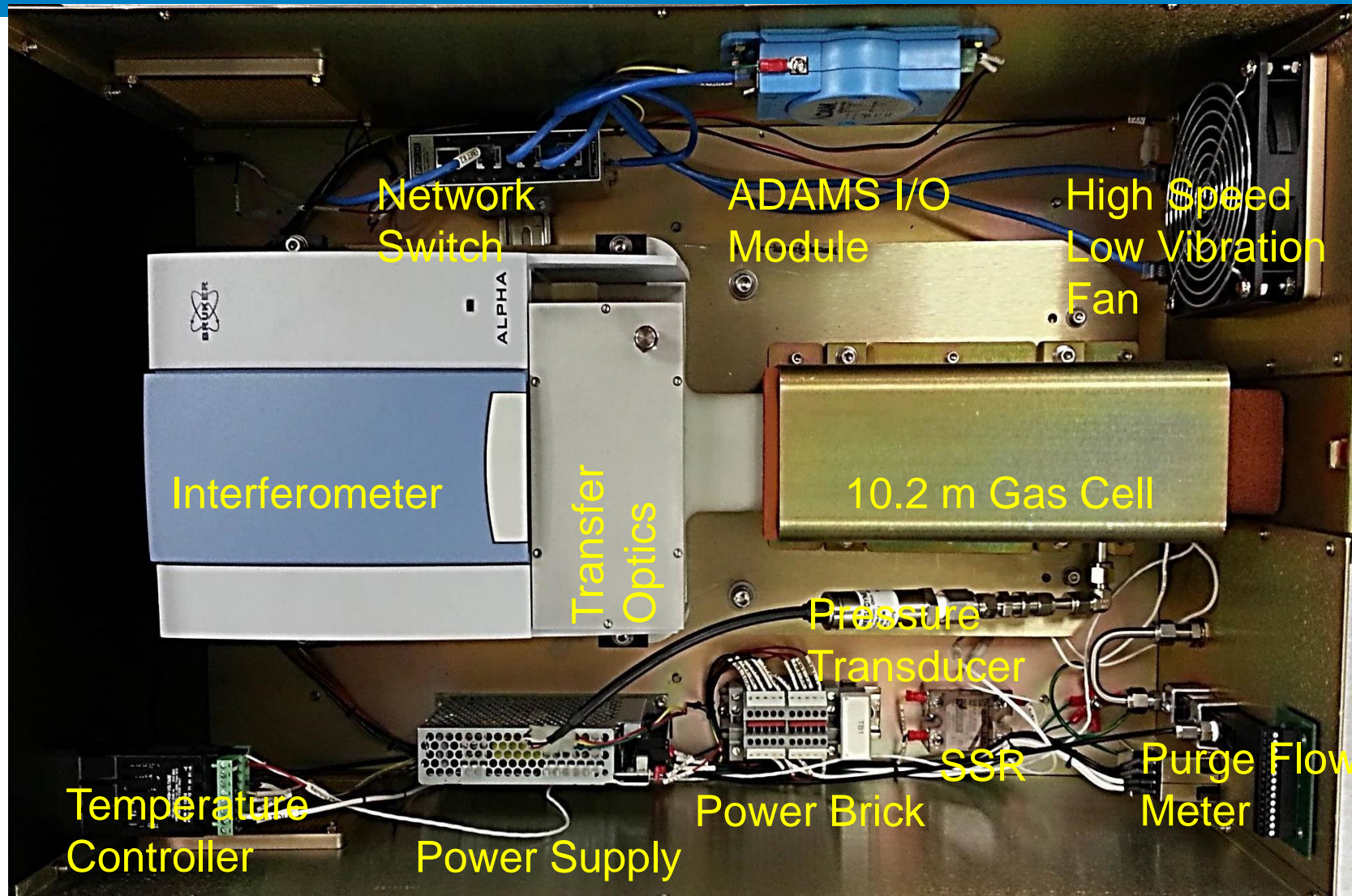

Network
Switch

ADAMS I/O
Module

High Speed
Low Vibration
Fan

Interferometer

Transfer
Optics

10.2 m Gas Cell

Pressure
Transducer

SSR

Purge Flow
Meter

Temperature
Controller

Power Supply

Power Brick



600/700 Series FTIR—Interferometer Optical Path

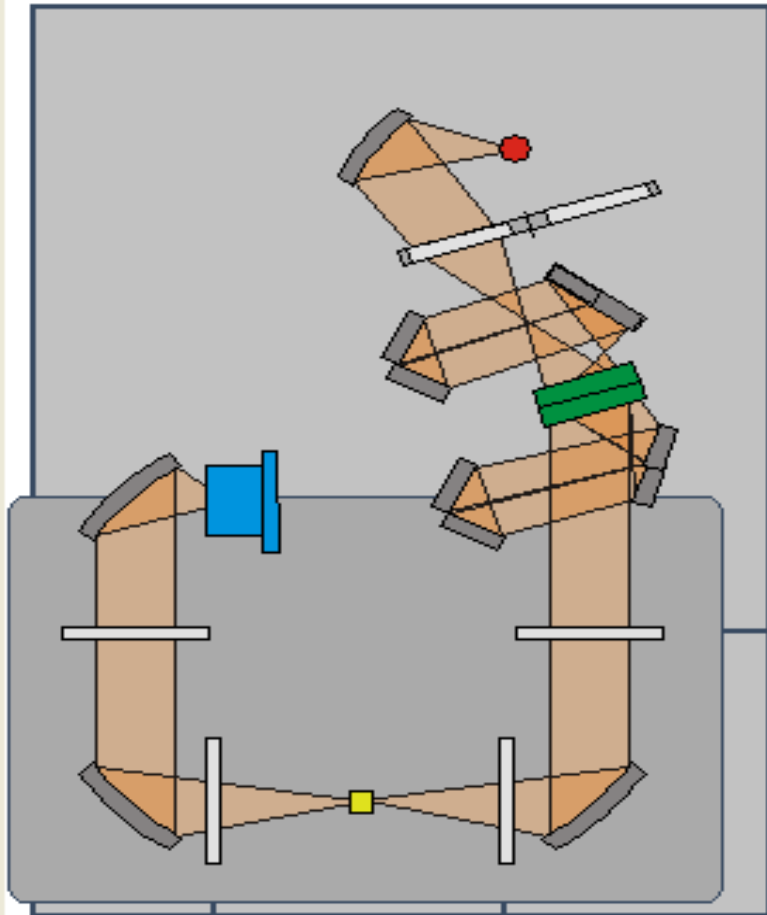



- 0.5 lpm N₂ or ZAG optics purge (maintaining rate).
- N₂ or ZAG for Baseline measurement
- Heated Sample Filter
- If 191° C is required:
 - Appropriate heated lines, heated pump, temp controllers
 - Sample probe (if needed)
- Consumables
 - 5 year IR Source replacement
 - 19 year Laser replacement
- Cell life
 - Varies based on operating conditions.



Importance of High Resolution

Resolution (cm ⁻¹)	Noise	Signal	S/N
0.8	0.000528	0.001016	1.93
1	0.000441	0.000913	2.07
2	0.000230	0.000549	2.39
4	0.000131	0.000370	2.82
8	0.000051	0.000164	3.24

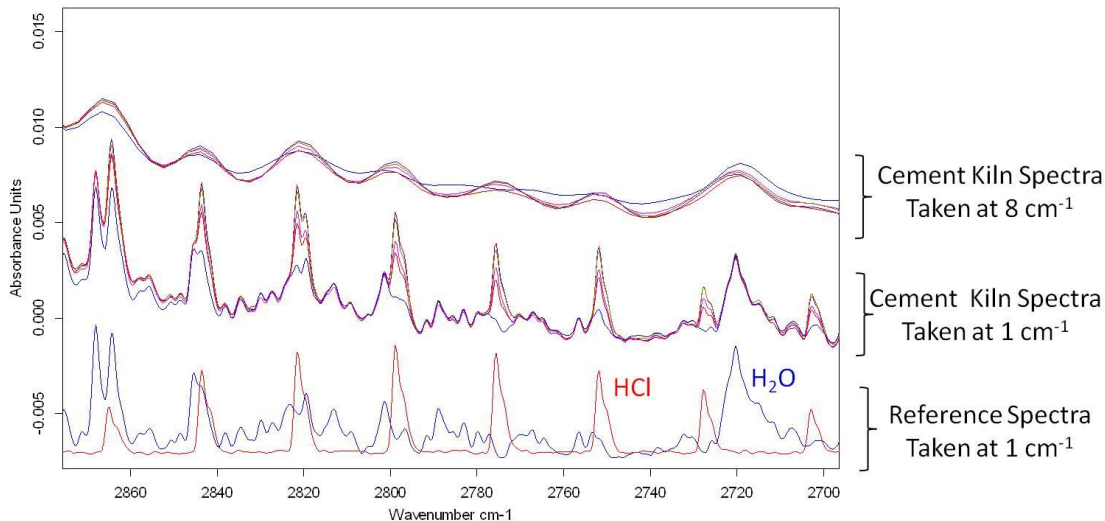
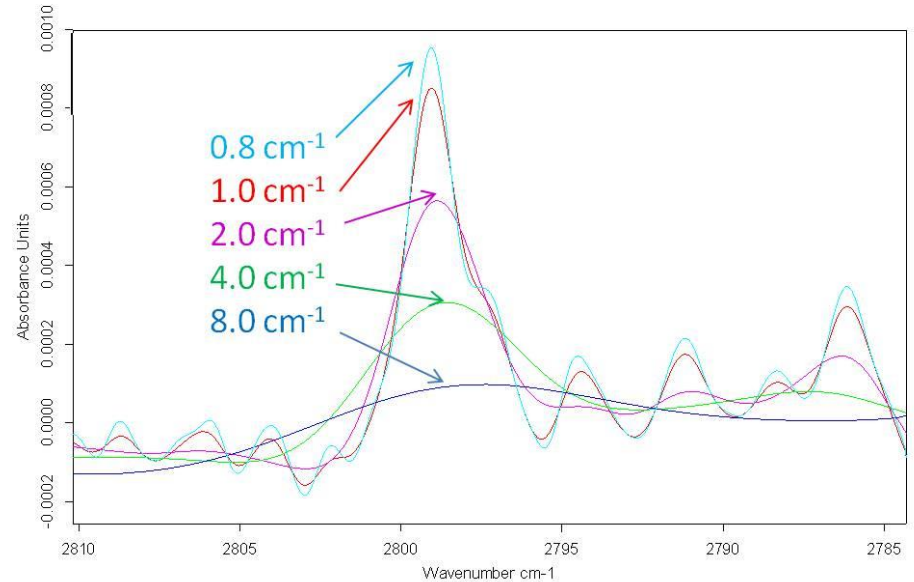

Low resolution has high signal to noise which is great for a single gas bottle.

However overlapping peaks are difficult to separate in real world examples



FTIR—Gas Spectra

Acetaldehyde:
CH₃CHO 65.3 ppm

Methanol:
CH₃OH 65.4 ppm

Ethanol:
C₂H₆O 51.7ppm

Formaldehyde:
HCHO 14.3ppm

Component	Det. Limit (ppm)
Acetaldehyde	0.14
Formaldehyde	0.08
Formic Acid	0.23
Methanol	0.05
Ethanol	0.42

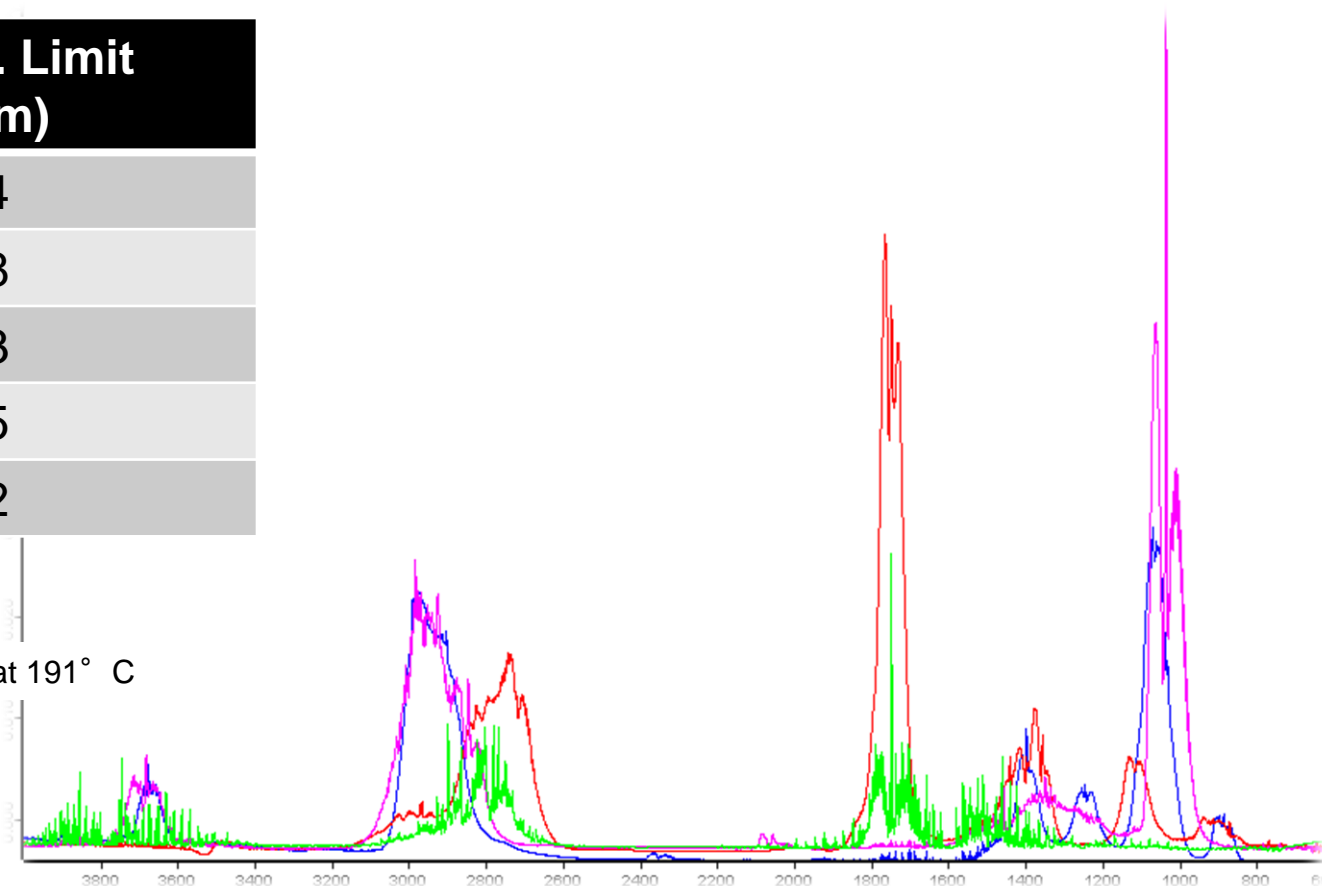

-Dry gas, single component values at 191° C



Ethanol Plant Spectrum

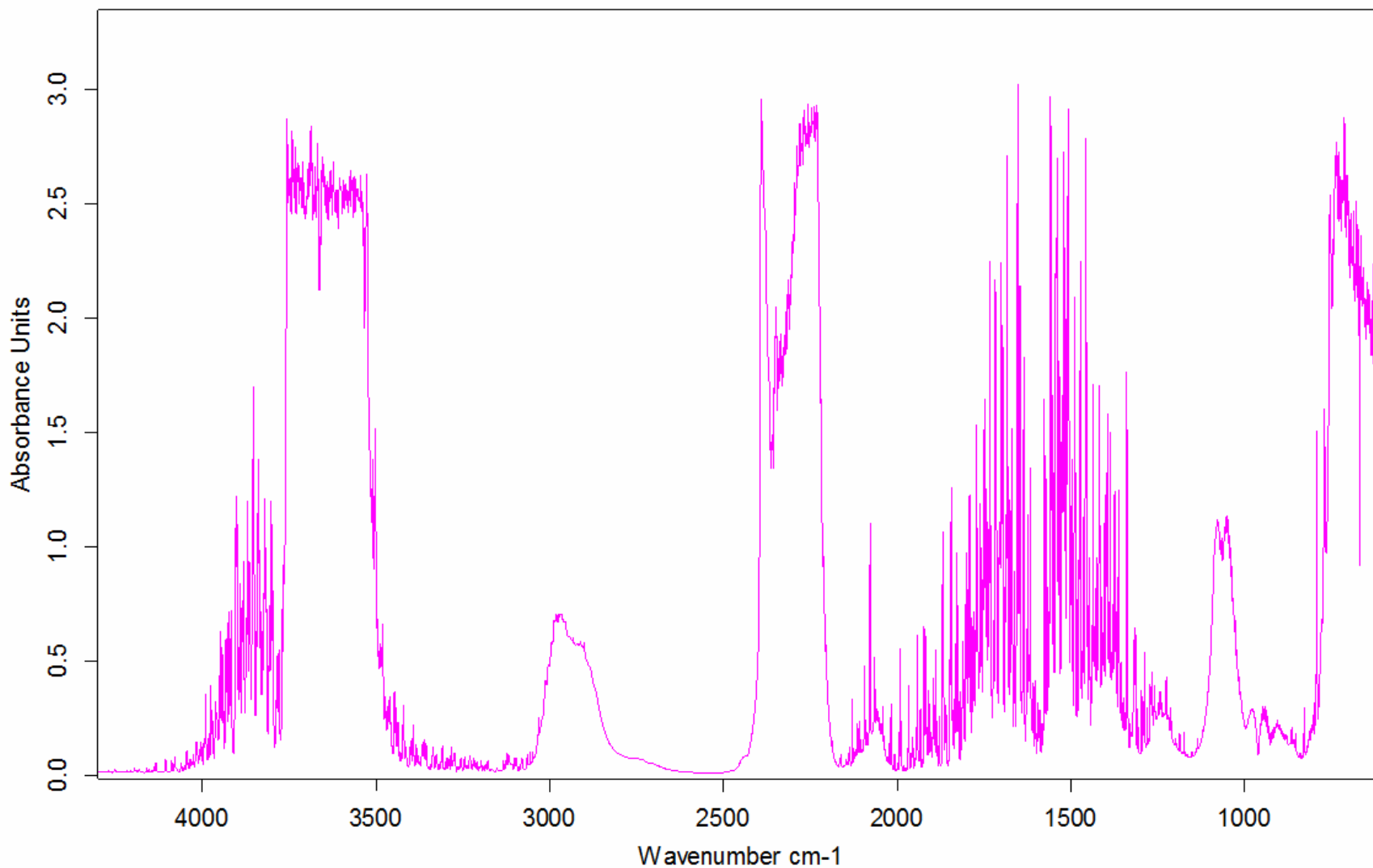



FTIR—Process

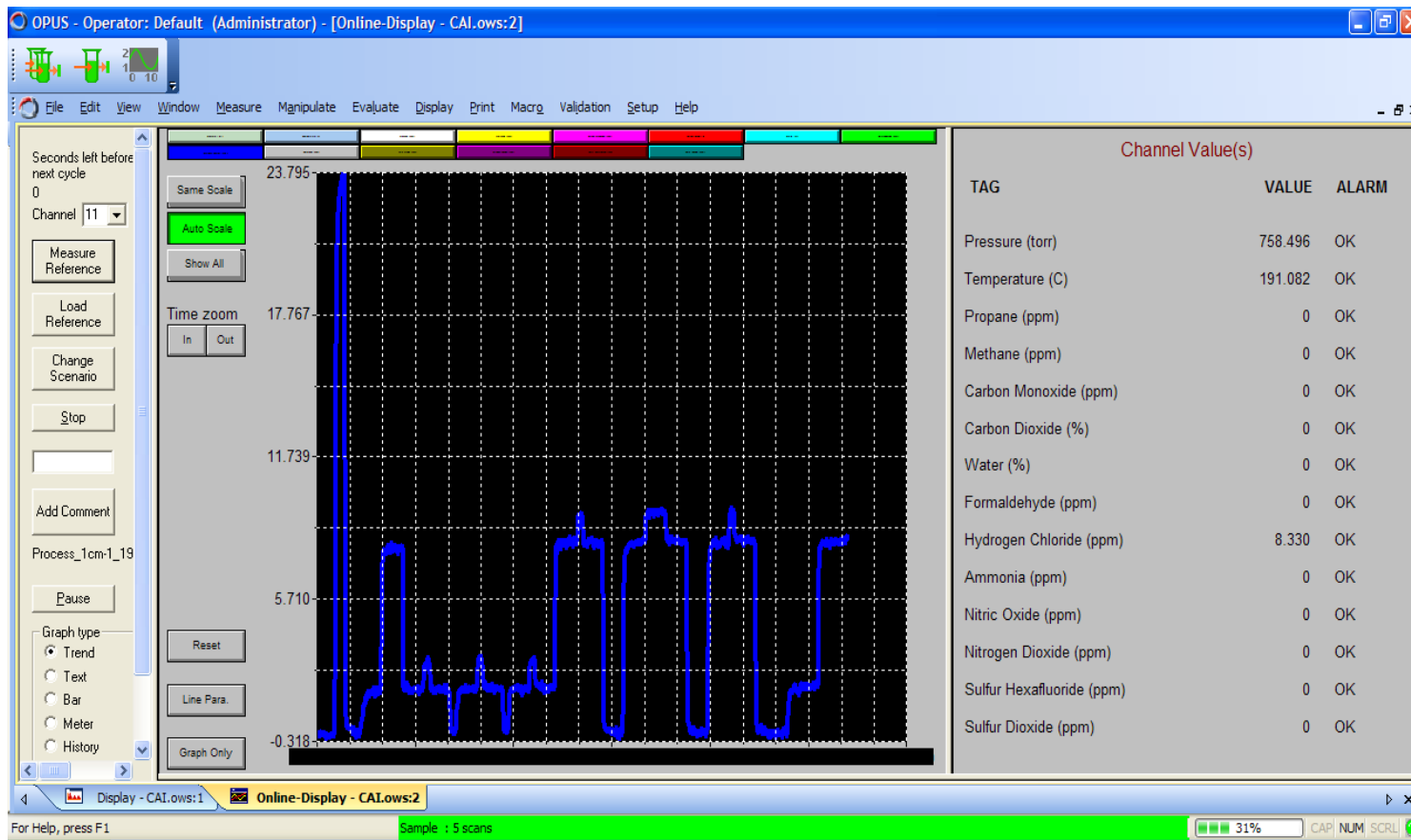

Includes auto ranging, pressure compensation, span correction, and LOD



FTIR - Installation at NE Ethanol Plant





- Other instruments can only record numbers
- FTIR records spectra *and* displays numbers
- Spectra can be reviewed and reanalyzed in the case of any issue



FTIR—Example Data

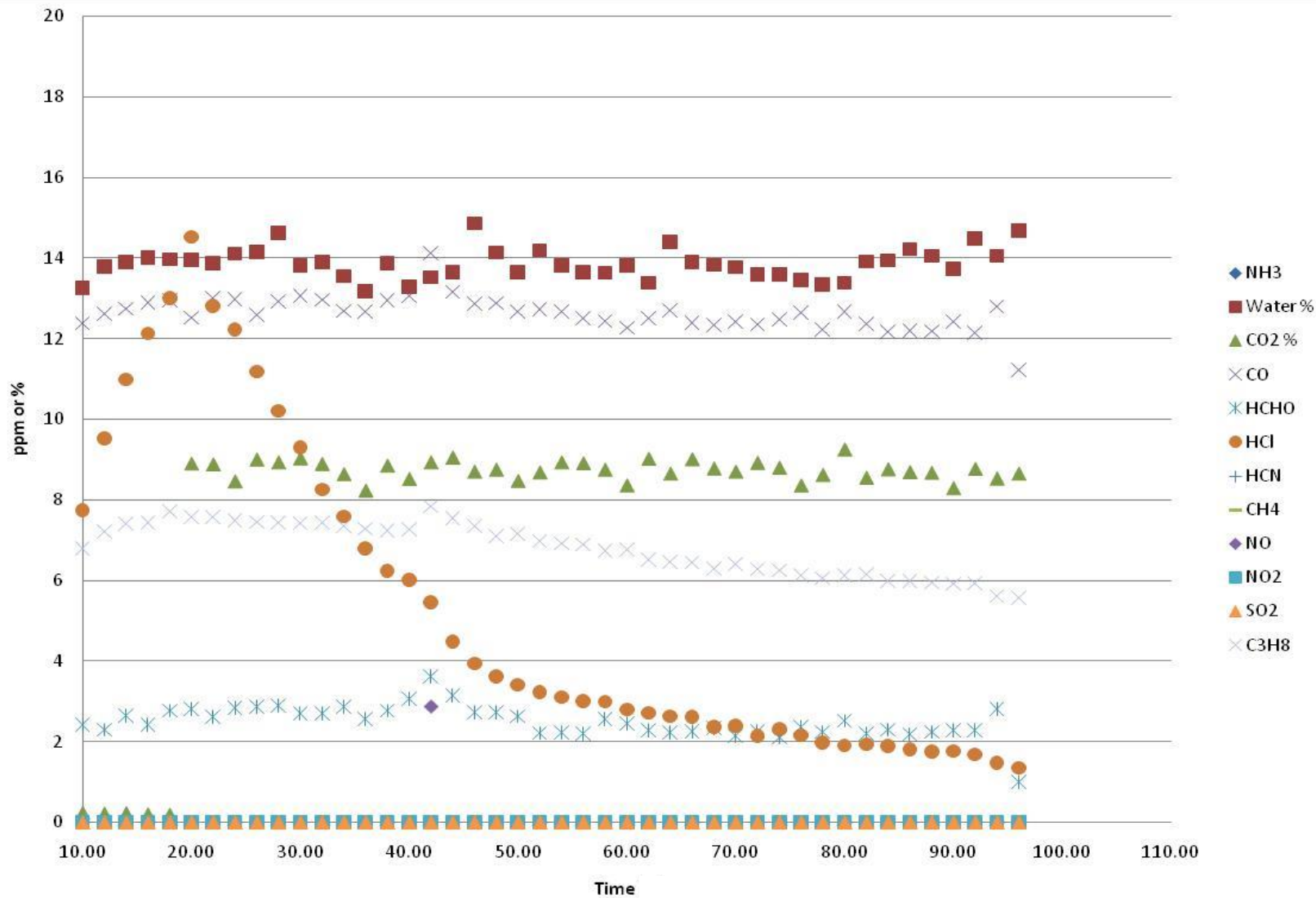

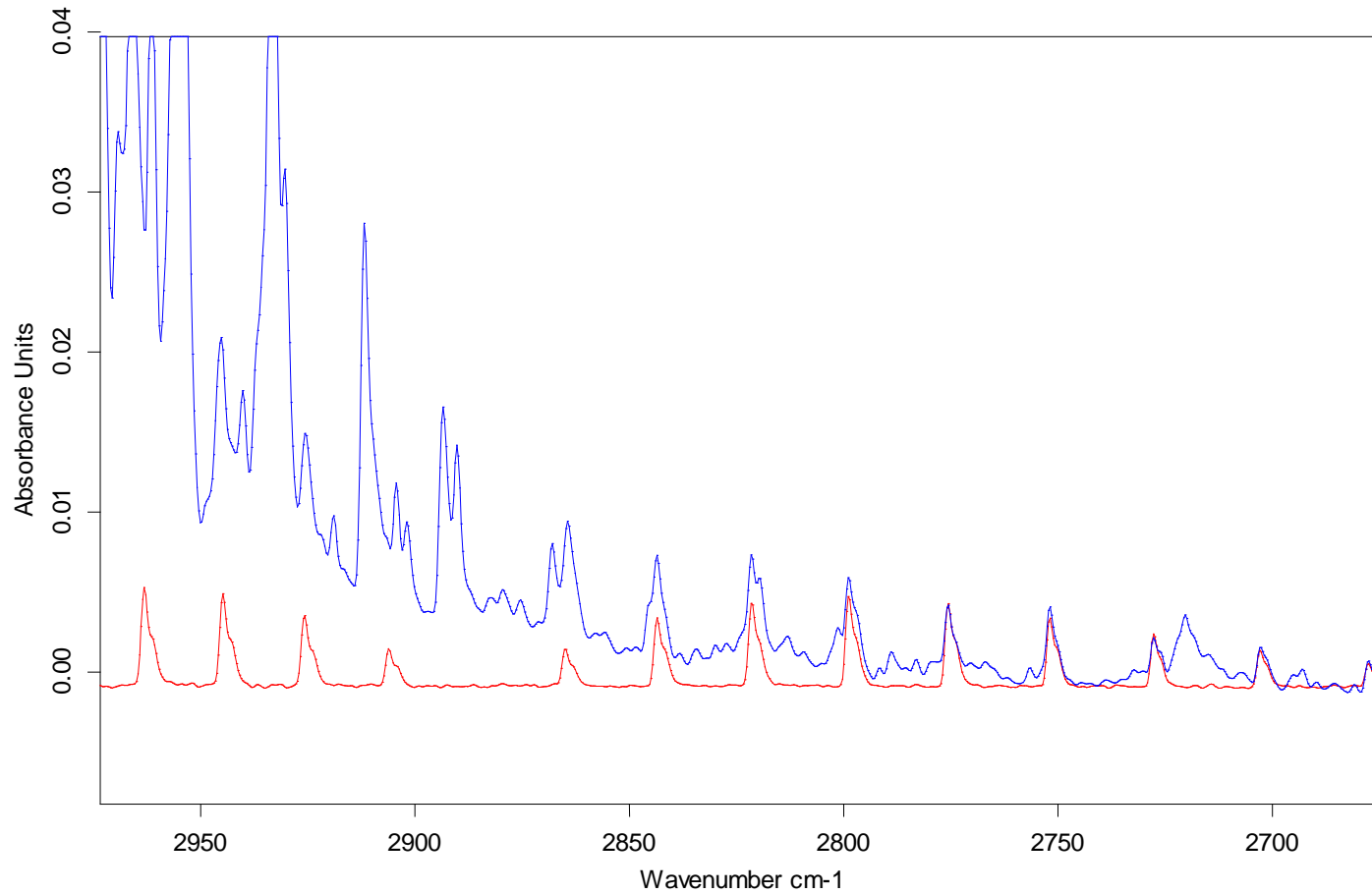

- HCl spectra was reviewed to confirm measurement results

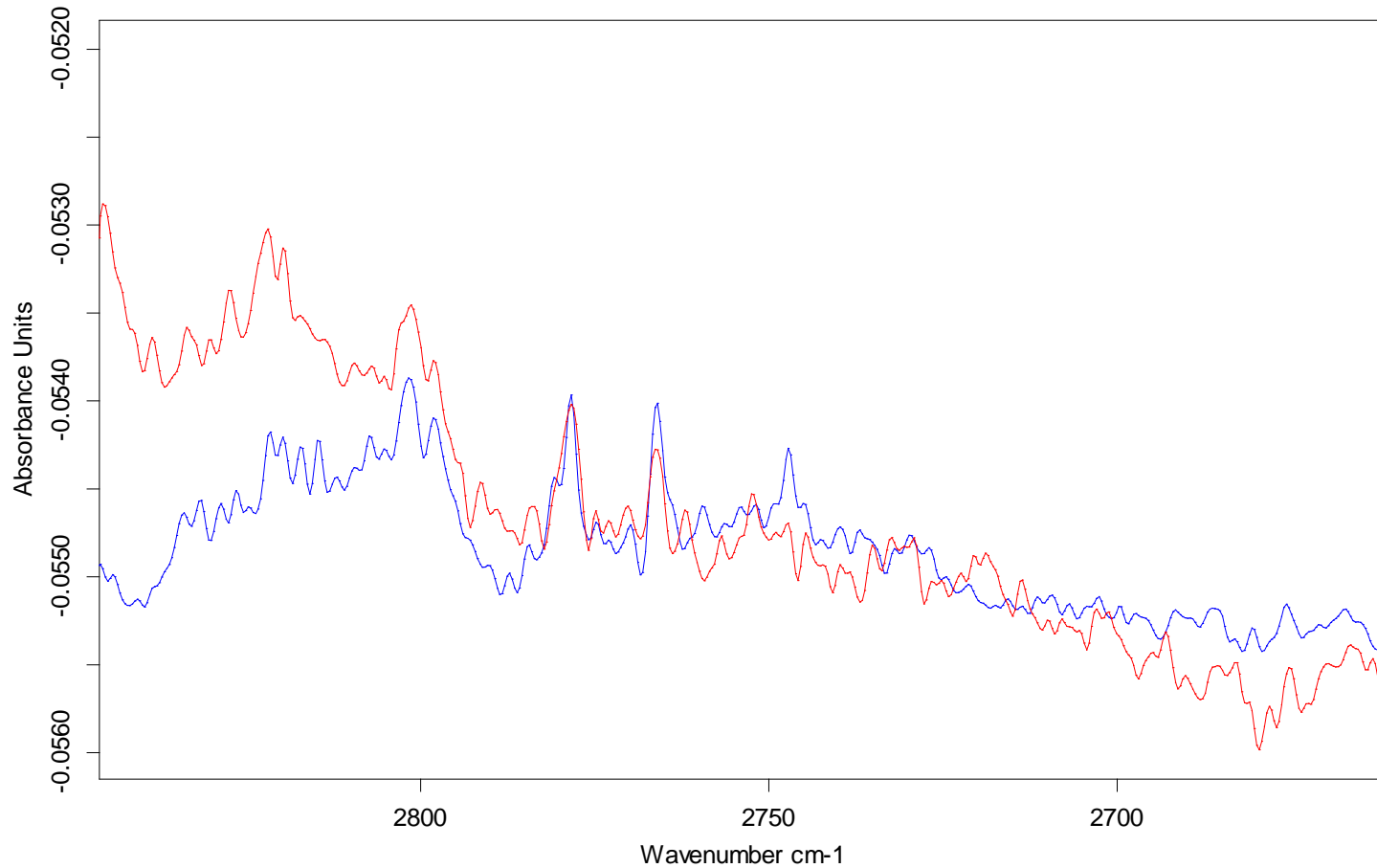

- HCHO spectra was reviewed to confirm measurement results



Current Application List

Cement
Stack Testing
Natural Gas Compressors
Diesel Engine
Catalysis
Pharmaceutical
Electric Utility Plant
Aerospace
Solid Fuel Burning
Municipal Waste Incineration
Process Control
Thermal Soil Remediation
Gas Purity
Jet Turbine
Ethanol Plant
Agriculture



- Laser – 19 year life
- IR Source - 5 year life, user replaceable
- Rocksolid™ Interferometer – Gold Mirrors, High throughput, Permanent alignment
- Process – Allows anyone to operate



CAI FTIR Advantages

- No liquid N₂ Required
- Small Form Factor
- No Sample Pressure Restrictions
- ZnSe Beam-Splitter (for Humidity Protection)
- 19 year Laser Life
- 5 Year IR Source Life
- Partial Least Squares (PLS) Quantification
- 316SS Electro-Polished Cell Standard
- Digital & Analog Inputs/Outputs
- Minimal Service Required
- Library Search Capability
- Easy-to-Maintain
- Permanently Aligned – Dual Corner Cube Designed Interferometer (Pinned)
- Macros:
 - Makes Repetitive Tasks Easier
 - Allows User to Easily Customize each Application